



1. Introduction.

In addition to information given in Kinetrol Installation, Operating & Maintenance Instructions (TD129 & 231 Kinetrol Actuators & Springs), this Safety Manual includes instructions relating to Functional Safety to IEC 61508-2:2010 for safety valve actuation packages typically used in industrial process plants.

A Functional Safety Assessment was completed by Sira Test & Certification Ltd and a copy of the certificate can be found at www.kinetrol.com

2. Terms & Abbreviations (used in this document).

- **Safety:** freedom from unacceptable risk.
- **Functional Safety:** part of the overall safety relating to the EUC and EUC control system that depends on the correct functioning of the E/E/PE safety-related systems and other risk reduction measures.
- **EUC:** Equipment Under Control.
- **E/E/PE:** Electrical/Electronic/Programmable Electronic.
- **SFF:** safe failure fraction defined by the ratio of the average failure rates of safe plus dangerous detected failures and safe plus dangerous failures.
- **PVST:** Partial Valve Stroke Testing.
- **PFD:** Probability of Dangerous Failure on Demand.
- **Fault tolerance:** the ability of a functional unit to continue to perform a required function in the presence of faults.

3. Product Arrangement.

The Figure 1 opposite shows how the quarter turn pneumatic actuator is the basic building block onto which other parts are added to provide the desired valve control function.

The Actuator is mounted to the Valve (or other device such as a Damper) via a bracket & coupling (unless the mounting flange of both parts allows a direct interface). This provides the double acting function where the valve will close on loss of electrical signal to the solenoid valve.

For fail-safe applications where a fail safe function occurs on loss of air supply, a spring return unit is fitted to the underside of the actuator. This provides the valve interface via the bracket & coupling or direct fitting if the interface allows (Note: size 60 see figure 4 where spring is above). The spring can be built for either clockwise or counter clockwise operation depending whether the fail-safe action is open or closed. The reversible spring version allows for this reversal more easily and contains fixed stops which also act as redundant stops to prevent some dangerous modes of failure.

In order to ensure maximum environmental protection of the spring assembly, the easiest utility fitting, lower centre of gravity and a lower probability of failure. SFF data applies to fitting of spring in both rotations.

A pneumatic solenoid valve is used to control the actuator position and can either be fitted directly to the Namur interface as shown or remotely piped to air ports available in this interface or ports located at the side of the actuator.

Figure 2 shows a typical double acting solenoid valve arrangement and Figure 3 that for a single acting or spring return assembly. Ports 3 & 5 are typically fitted with exhaust silencers and/or flow restrictors.

A Kinetrol limit switch box (either a ULS or XLS type) can be fitted directly to the top of the actuator (models 03 to 15) as shown in figure 1 or fitted via a suitable bracket and coupling as with other makes of switch box or larger Kinetrol models 16-60.

Note: the protection given to the actuator top bearing is improved with a direct/close mounted switch box.

As an alternative to a switch box, a PVST device may be fitted. Ask Kinetrol for details.

Figure 1 shows the optional Clear Cone monitor fitted which also helps to protect the moving parts against corrosion as well as providing improved visual position indication.

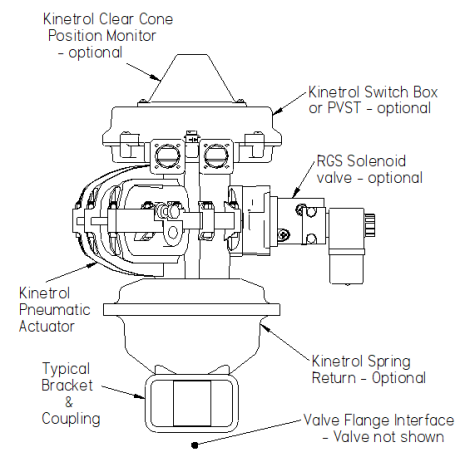
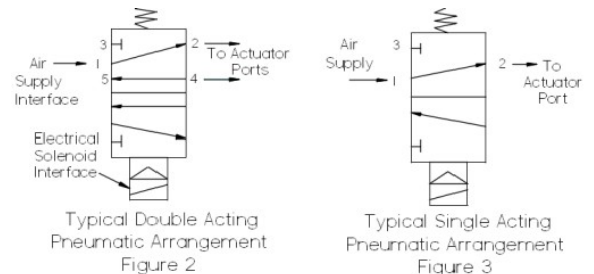

Figure 1 Typical Kinetrol Actuator Arrangement



Typical Double Acting Pneumatic Arrangement
Figure 2

Typical Single Acting Pneumatic Arrangement
Figure 3

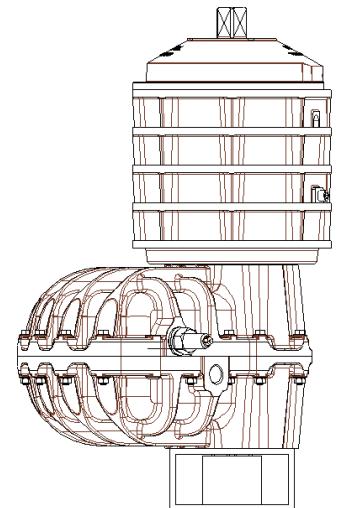

Figure 4 Model 60 Spring arrangement



4. Functional Constraints

The device, as configured, has functional constraints in its application. These can be summarised by the following:

- The mounting of the unit to the bracket/valve should be as described on page 1 of TD129.
- The air/gas supply should be as specified on page 1 of TD129
- Actuator/spring operation, maintenance & adjustment should be as specified on page 3 of TD129
- In high vibration environmental conditions (greater than 4g @ 100Hz), contact Kinetrol for advice if vibration levels are higher.
- For operating constraints of the limit switch box (if fitted) refer to the switch box IOM as supplied or contact Kinetrol for a copy quoting the unit serial number or part number.
- For functional constraints for the Solenoid Valve, refer to valve supplier quoting their part number or if supplied by Kinetrol refer to manual as supplied.

5. Functional Failure Modes.

The mechanical simplicity of the Kinetrol actuator design, allows a relatively straight forward analysis of the possible failure modes of its constituent parts. Therefore the failures become very infrequent as the Functional Safety Certificate suggests and failure of components is derived mainly from generic industry data. This ensures the design comprises 'Type A' components. The 'hardware fault tolerance' is assumed zero.

The critical items that contribute most to the theoretical failure modes are:

- Process Valve failure data must be taken into account for the overall valve/actuator assembly and must be obtained from the valve manufacture.
- Air supply failure with double acting versions has not been considered.
- FMEA data with RGS Solenoid valves is included in one double acting version.
- The failure analysis with other makes/types of Solenoid Valve use manufacturers data.
- The use of a PVST device will increase the SFF and reduce the PFD in all cases but the improvement is greater in sizes 16-60 with both spring return and double acting.
- Spring unit (if fitted) is mounted beneath the actuator and not above except for size 60. (for reasons described in section 3)
- The switch box is fitted where possible directly to the top of the actuator in order to prevent any possibility of ingress of fluid or dust to the actuator upper bearing.
- Single spring pack FMEA analysis shows a lower failure mode than with multiple spring packs.
- Failure of fasteners within the actuator/spring unit contribute to the theoretical failure modes and therefore Kinetrol procedures during any rebuild must be followed closely including tightening screws to the correct torques and the use of thread adhesives where applicable.

The failure mode analysis, assumes a proof test interval of 8,760 hours (one year) and mean time to repair of 8 hours. With the application of a PVST, the test interval is assumed to reduce to one tenth of this. The following tables described below show the failure rate of various products combination and the probability of failure on low demand.

Kinetrol TD 138 section 3 specifies pre-maintenance checks that are applicable to all sizes of Kinetrol actuator. Section 4 lists checks that can be made once a faulty actuator has been dismantled. If in doubt, contact Kinetrol for advice.

6. Systematic Integrity.

Kinetrol internal processes and procedures have also been under scrutiny to ensure compliance with IEC 61508. Kinetrol remains in an enviable position of manufacture of vital processes in house and systematic faults can therefore be identified and systems altered to remove their effect from within the organisation. System integrity is therefore high and complies with the requirements for a Safety Integrity Level (SIL) 3.

Users of the product as described above, must ensure that the assembly is fitted to the valve and used in compliance with statements already made in order to avoid systematic failures that are outside the control of Kinetrol.

Issue E	RCC 19-05-21	KINETROL Trading Estate Farnham Surrey England	Doc. No. TD170 Page 2 of 15
------------	-----------------	-------------------------------------------------------	--------------------------------



Product Safety Manual – Kinetrol Actuator/Spring & Limit Switch Box

Arrangement one: Spring return mounted next to valve (valve not included); Actuator on valve; switch box mounted as noted either direct on the actuator or indirectly coupled

Kinetrol Part	No. of Springs	No. of vanes	No. of vane bolts	Switch box included?	Switch Box Direct Mount	PVST? (Partial valve stroke test)	λ_{DD} FITS	λ_{DU} FITS	λ_S FITS	$\lambda_{no\ effect}$ FITS	SFF %	HFT	PFD _{AVG}	SIL	Demand Mode
02**12*	1	1	2	Yes	Yes	No	0	46	793	3488	95	0	0.0002	3	Low
02**12*	1	1	2	Yes	Yes	Yes	19	27	793	3488	97	0	0.0001	3	Low
02**12*	1	1	2	No	No	No	0	46	685	3128	94	0	0.0002	3	Low
02**12*	1	1	2	No	No	Yes	19	27	685	3128	96	0	0.0001	3	Low
03**12*	1	1	2	Yes	Yes	No	0	46	793	3488	95	0	0.0002	3	Low
03**12*	1	1	2	Yes	Yes	Yes	19	27	793	3488	97	0	0.0001	3	Low
03**12*	1	1	2	No	No	No	0	46	685	3128	94	0	0.0002	3	Low
03**12*	1	1	2	No	No	Yes	19	27	685	3128	96	0	0.0001	3	Low
05**12*	1	1	2	Yes	Yes	No	0	46	793	3488	95	0	0.0002	3	Low
05**12*	1	1	2	Yes	Yes	Yes	19	27	793	3488	97	0	0.0001	3	Low
05**12*	1	1	2	No	No	No	0	46	685	3128	94	0	0.0002	3	Low
05**12*	1	1	2	No	No	Yes	19	27	685	3128	96	0	0.0001	3	Low
07**12*	1	1	4	Yes	Yes	No	0	52	793	3492	94	0	0.0002	3	Low
07**12*	1	1	4	Yes	Yes	Yes	23	30	793	3492	97	0	0.0001	3	Low
07**12*	1	1	4	No	No	No	0	52	685	3132	93	0	0.0002	3	Low
07**12*	1	1	4	No	No	Yes	23	30	685	3132	96	0	0.0001	3	Low
07**12*-4000	1	1	4	Yes	Yes	No	0	52	793	3492	94	0	0.0002	3	Low
07**12*-4000	1	1	4	Yes	Yes	Yes	23	30	793	3492	97	0	0.0001	3	Low
07**12*-4000	1	1	4	No	No	No	0	52	685	3132	93	0	0.0002	3	Low
07**12*-4000	1	1	4	No	No	Yes	23	30	685	3132	96	0	0.0001	3	Low
08**12*	1	1	4	Yes	Yes	No	0	52	793	3492	94	0	0.0002	3	Low
08**12*	1	1	4	Yes	Yes	Yes	23	30	793	3492	97	0	0.0001	3	Low
08**12*	1	1	4	No	No	No	0	52	685	3132	93	0	0.0002	3	Low



Product Safety Manual – Kinnetrol Actuator/Spring & Limit Switch Box

Kinnetrol Part	No. of Springs	No. of vanes	No. of vane bolts	Switch box included?	Switch Box Direct Mount	PVST? (Partial valve stroke test)	λ_{DD} FITS	λ_{DU} FITS	λ_S FITS	$\lambda_{no\ effect}$ FITS	SFF %	HFT	PFD _{AVG}	SIL	Demand Mode
08**12*	1	1	4	No	No	Yes	23	30	685	3132	96	0	0.0001	3	Low
09**12*	1	1	4	Yes	Yes	No	0	52	793	3492	94	0	0.0002	3	Low
09**12*	1	1	4	Yes	Yes	Yes	23	30	793	3492	97	0	0.0001	3	Low
09**12*	1	1	4	No	No	No	0	52	685	3132	94	0	0.0002	3	Low
09**12*	1	1	4	No	No	Yes	23	30	685	3132	96	0	0.0001	3	Low
09**12*- 4200	1	1	4	Yes	Yes	No	0	52	793	3492	94	0	0.0002	3	Low
09**12*- 4200	1	1	4	Yes	Yes	Yes	23	30	793	3492	97	0	0.0001	3	Low
09**12*- 4200	1	1	4	No	No	No	0	52	685	3132	93	0	0.0002	3	Low
09**12*- 4200	1	1	4	No	No	Yes	23	30	685	3132	96	0	0.0001	3	Low
10**12*	1	1	4	Yes	Yes	No	0	52	793	3492	94	0	0.0002	3	Low
10**12*	1	1	4	Yes	Yes	Yes	23	30	793	3492	97	0	0.0001	3	Low
10**12*	1	1	4	No	No	No	0	52	685	3132	93	0	0.0002	3	Low
10**12*	1	1	4	No	No	Yes	23	30	685	3132	96	0	0.0001	3	Low
10**12*- 5800	1	1	4	Yes	Yes	No	0	52	793	3492	94	0	0.0002	3	Low
10**12*- 5800	1	1	4	Yes	Yes	Yes	23	30	793	3492	97	0	0.0001	3	Low
10**12*- 5800	1	1	4	No	No	No	0	52	685	3132	93	0	0.0002	3	Low
10**12*- 5800	1	1	4	No	No	Yes	23	30	685	3132	96	0	0.0001	3	Low
12**12*	1	1	6	Yes	Yes	No	0	57	793	3496	93	0	0.0002	3	Low
12**12*	1	1	6	Yes	Yes	Yes	25	31	793	3496	96	0	0.0001	3	Low
12**12*	1	1	6	No	No	No	0	57	685	3135	92	0	0.0002	3	Low
12**12*	1	1	6	No	No	Yes	25	31	685	3135	96	0	0.0001	3	Low

Issue
E

RCC
19-05-21

KINETROL

Trading Estate Farnham Surrey England

Doc. No. TD170
Page 4 of 15



Product Safety Manual – Kinetro Actuator/Spring & Limit Switch Box

Kinetro Part	No. of Springs	No. of vanes	No. of vane bolts	Switch box included?	Switch Box Direct Mount	PVST? <i>(Partial valve stroke test)</i>	λ_{DD} FITS	λ_{DU} FITS	λ_S FITS	$\lambda_{no\ effect}$ FITS	SFF %	HFT	PFD _{AVG}	SIL	Demand Mode
12**12*-4300	1	1	6	Yes	Yes	No	0	57	793	3496	93	0	0.0002	3	Low
12**12*-4300	1	1	6	Yes	Yes	Yes	25	31	793	3496	96	0	0.0001	3	Low
12**12*-4300	1	1	6	No	No	No	0	57	685	3135	92	0	0.0002	3	Low
12**12*-4300	1	1	6	No	No	Yes	25	31	685	3135	96	0	0.0001	3	Low
12**12*-4400	2	1	6	Yes	Yes	No	0	82	793	6591	91	0	0.0003	3	Low
12**12*-4400	2	1	6	Yes	Yes	Yes	30	44	793	6591	95	0	0.0002	3	Low
12**12*-4400	2	1	6	No	No	No	0	74	685	6215	90	0	0.0003	3	Low
12**12*-4400	2	1	6	No	No	Yes	30	44	685	6215	94	0	0.0002	3	Low
14**12*	1	1	8	Yes	Yes	No	0	61	793	3500	93	0	0.0003	3	Low
14**12*	1	1	8	Yes	Yes	Yes	28	33	793	3500	96	0	0.0001	3	Low
14**12*	1	1	8	No	No	No	0	61	685	3136	92	0	0.0003	3	Low
14**12*	1	1	8	No	No	Yes	28	33	685	3136	96	0	0.0001	3	Low
14**12*-4900	2	1	8	Yes	Yes	No	0	80	793	6596	91	0	0.0004	3	Low
14**12*-4900	2	1	8	Yes	Yes	Yes	32	48	793	6596	95	0	0.0002	3	Low
14**12*-4900	2	1	8	No	No	No	0	80	685	6235	90	0	0.0004	3	Low
14**12*-4900	2	1	8	No	No	Yes	32	48	685	6235	94	0	0.0002	3	Low
14**12*-5000	1	1	8	Yes	Yes	No	0	61	793	3500	93	0	0.0003	3	Low

Issue E

RCC
19-05-21

KINETROL

Trading Estate Farnham Surrey England

Doc. No. TD170
Page 5 of 15



Product Safety Manual – Kinetrol Actuator/Spring & Limit Switch Box

Kinetrol Part	No. of Springs	No. of vanes	No. of vane bolts	Switch box included?	Switch Box Direct Mount	PVST? (Partial valve stroke test)	λ_{DD} FITS	λ_{DU} FITS	λ_S FITS	$\lambda_{no\ effect}$ FITS	SFF %	HFT	PFD _{AVG}	SIL	Demand Mode
14**12*-5000	1	1	8	Yes	Yes	Yes	28	33	793	3500	96	0	0.0001	3	Low
14**12*-5000	1	1	8	No	No	No	0	61	685	3136	92	0	0.0003	3	Low
14**12*-5000	1	1	8	No	No	Yes	28	33	685	3136	96	0	0.0001	3	Low
15**12*	1	1	8	Yes	Yes	No	0	61	793	3500	93	0	0.0003	3	Low
15**12*	1	1	8	Yes	Yes	Yes	28	33	793	3500	96	0	0.0001	3	Low
15**12*	1	1	8	No	No	No	0	61	685	3136	92	0	0.0003	3	Low
15**12*	1	1	8	No	No	Yes	28	33	685	3136	96	0	0.0001	3	Low
16**12*	1	1	8	Yes	Yes	No	0	61	793	3500	93	0	0.0003	3	Low
16**12*	1	1	8	Yes	Yes	Yes	28	33	793	3500	96	0	0.0001	3	Low
16**12*	1	1	8	No	No	No	0	61	685	3136	92	0	0.0003	3	Low
16**12*	1	1	8	No	No	Yes	28	33	685	3136	96	0	0.0001	3	Low
16**12*-6100	1	1	8	Yes	Yes	No	0	61	793	3500	93	0	0.0003	3	Low
16**12*-6100	1	1	8	Yes	Yes	Yes	28	33	793	3500	96	0	0.0001	3	Low
16**12*-6100	1	1	8	No	No	No	0	61	685	3136	92	0	0.0003	3	Low
16**12*-6100	1	1	8	No	No	Yes	28	33	685	3136	96	0	0.0001	3	Low
18**12*	1	1	8	Yes	Yes	No	0	61	793	3500	93	0	0.0003	3	Low
18**12*	1	1	8	Yes	Yes	Yes	28	33	793	3500	96	0	0.0001	3	Low
18**12*	1	1	8	No	No	No	0	61	685	3136	92	0	0.0003	3	Low
18**12*	1	1	8	No	No	Yes	28	33	685	3136	96	0	0.0001	3	Low
18**12*-7000	1	1	8	Yes	Yes	No	0	61	793	3500	93	0	0.0003	3	Low
18**12*-7000	1	1	8	Yes	Yes	Yes	28	33	793	3500	96	0	0.0001	3	Low

Issue E

RCC
19-05-21

KINETROL

Trading Estate Farnham Surrey England

Doc. No. TD170
Page 6 of 15



Product Safety Manual – Kinnetrol Actuator/Spring & Limit Switch Box

Kinnetrol Part	No. of Springs	No. of vanes	No. of vane bolts	Switch box included?	Switch Box Direct Mount	PVST? (Partial valve stroke test)	λ_{DD} FITS	λ_{DU} FITS	λ_S FITS	$\lambda_{no\ effect}$ FITS	SFF %	HFT	PFD _{AVG}	SIL	Demand Mode
18**12*-7000	1	1	8	No	No	No	0	61	685	3136	92	0	0.0003	3	Low
18**12*-7000	1	1	8	No	No	Yes	28	33	685	3136	96	0	0.0001	3	Low
20**12*	2	2	8	Yes	Yes	No	0	189	1240	10060	87	0	0.0008	2	Low
20**12*	2	2	8	Yes	Yes	Yes	94	95	1240	10060	94	0	0.0004	3	Low
20**12*	2	2	8	No	No	No	0	188	1127	10025	86	0	0.0008	2	Low
20**12*	2	2	8	No	No	Yes	94	94	1127	10025	93	0	0.0004	3	Low
20**12*-8000	1	2	8	Yes	Yes	No	0	61	793	3500	93	0	0.0003	3	Low
20**12*-8000	1	2	8	Yes	Yes	Yes	28	33	793	3500	96	0	0.0001	3	Low
20**12*-8000	1	2	8	No	No	No	0	61	685	3136	92	0	0.0003	3	Low
20**12*-8000	1	2	8	No	No	Yes	28	33	685	3136	96	0	0.0001	3	Low
20**12*-7300	3	2	8	Yes	Yes	No	0	195	1418	10813	88	0	0.0009	2	Low
20**12*-7300	3	2	8	Yes	Yes	Yes	96	99	1418	10813	94	0	0.0008	3	Low
20**12*-7300	3	2	8	No	No	No	0	195	1309	10421	87	0	0.001	2	Low
20**12*-7300	3	2	8	No	No	Yes	96	99	1310	10421	94		0.0004	3	Low
21**12*	2	1	8	Yes	Yes	No	0	180	1178	9557	87%	0	0.000788	2	Low
21**12*	2	1	8	Yes	Yes	Yes	92	90	1178	9557	93%	0	0.000397	3	Low
21**12*	2	1	8	No	No	No	0	179	1071	9524	86%	0	0.000784	2	Low
21**12*	2	1	8	No	No	Yes	92	89	1071	9524	93%	0	0.000393	3	Low
21**12*-7300	3	1	8	Yes	Yes	No	0	185	1347	10272	88%	0	0.000813	2	Low



Product Safety Manual – Kinnetrol Actuator/Spring & Limit Switch Box

Kinnetrol Part	No. of Springs	No. of vanes	No. of vane bolts	Switch box included?	Switch Box Direct Mount	PVST? <i>(Partial valve stroke test)</i>	λ_{DD} FITS	λ_{DU} FITS	λ_S FITS	$\lambda_{no\ effect}$ FITS	SFF %	HFT	PFD _{AVG}	SIL	Demand Mode
21**12*-7300	3	1	8	Yes	Yes	Yes	94	94	1347	10272	94%	0	0.000413	3	Low
21**12*-7300	3	1	8	No	No	No	0	185	1244	9900	87%	0	0.000813	2	Low
21**12*-7300	3	1	8	No	No	Yes	94	94	1245	9900	93%	0	0.000413	3	Low
30**12*	3	3	8	Yes	Yes	No	0	248	1890	16850	88	0	0.0011	2	Low
30**12*	3	3	8	Yes	Yes	Yes	124	125	1890	16850	94	0	0.0005	3	Low
30**12*	3	3	8	No	No	No	0	247	1779	16484	88	0	0.001	2	Low
30**12*	3	3	8	No	No	Yes	124	124	1779	16484	94	0	0.0005	3	Low
30**12*-7600	3	3	8	Yes	Yes	No	0	221	2048	9777	90	0	0.001	2	Low
30**12*-7600	3	3	8	Yes	Yes	Yes	106	114	2047	9777	95	0	0.0005	3	Low
30**12*-7600	3	3	8	No	No	No	0	221	1940	9416	90	0	0.001	2	Low
30**12*-7600	3	3	8	No	No	Yes	102	100	1940	9416	95	0	0.0004	3	Low
30**12*-8300	2	3	8	Yes	Yes	No	0	189	1240	10060	87	0	0.0008	2	Low
30**12*-8300	2	3	8	Yes	Yes	Yes	94	95	1240	10060	94	0	0.0004	3	Low
30**12*-8300	2	3	8	No	No	No	0	188	1127	10025	86	0	0.0008	2	Low
30**12*-8300	2	3	8	No	No	Yes	94	94	1127	10025	93	0	0.0004	3	Low
30**12*-7800	5	3	8	Yes	Yes	No	0	255	1642	15929	87	0	0.001	2	Low
30**12*-7800	5	3	8	Yes	Yes	Yes	116	139	1642	15929	93	0	0.0006	3	Low



Product Safety Manual – Kinetro Actuator/Spring & Limit Switch Box

Kinetro Part	No. of Springs	No. of vanes	No. of vane bolts	Switch box included?	Switch Box Direct Mount	PVST? (Partial valve stroke test)	λ_{DD} FITS	λ_{DU} FITS	λ_S FITS	$\lambda_{no\ effect}$ FITS	SFF %	HFT	PFD _{AVG}	SIL	Demand Mode
30**12*-7800	5	3	8	No	No	No	0	255	1534	15568	86	0	0.0011	2	Low
30**12*-7800	5	3	8	No	No	Yes	116	139	1534	15568	92	0	0.0006	3	Low
40**8100	2	1	8	Yes	Yes	No	0	298	868	423	74%	0	0.0002	2	Low
40**8100	2	1	8	Yes	Yes	Yes	172	124	689	423	87%	0	0.0001	3	Low
40**8100	2	1	8	No	No	No	0	298	815	262	73%	0	0.0002	2	Low
40**8100	2	1	8	No	No	Yes	172	125	815	262	89%	0	0.0001	3	Low
40**8200	3	1	8	Yes	Yes	No	0	337	1182	423	78%	0	0.0002	2	Low
40**8200	3	1	8	Yes	Yes	Yes	192	145	1004	423	89%	0	0.0001	3	Low
40**8200	3	1	8	No	No	No	0	336	1128	262	77%	0	0.0002	2	Low
40**8200	3	1	8	No	No	Yes	192	145	1128	262	90%	0	0.0001	3	Low
40**12*	4	1	8	Yes	Yes	No	0	341	1182	423	78%	0	0.0002	2	Low
40**12*	4	1	8	Yes	Yes	Yes	193	89	480	423	88%	0	0.0001	3	Low
40**12*	4	1	8	No	No	No	0	312	604	262	66%	0	0.0002	2	Low
40**12*	4	1	8	No	No	Yes	193	90	606	262	90%	0	0.0001	3	Low
60**8400	4	1	8	Yes	Yes	No	0	334	816	578	71%	0	0.0002	2	Low
60**8400	4	1	8	Yes	Yes	Yes	184	139	816	578	88%	0	0.0001	3	Low
60**8400	4	1	8	No	No	No	0	326	770	416	70%	0	0.0002	2	Low
60**8400	4	1	8	No	No	Yes	185	140	771	416	87%	0	0.0001	3	Low
60**8500	5	1	8	Yes	Yes	No	0	397	1340	578	77%	0	0.0002	2	Low
60**8500	5	1	8	Yes	Yes	Yes	217	171	1340	578	90%	0	0.0001	3	Low
60**8500	5	1	8	No	No	No	0	388	1292	416	77%	0	0.0002	2	Low
60**8500	5	1	8	No	No	Yes	217	171	1292	416	90%	0	0.0001	3	Low
60**12*	6	1	8	Yes	Yes	No	0	401	1340	578	77%	0	0.0002	2	Low
60**12*	6	1	8	Yes	Yes	Yes	218	174	1340	578	90%	0	0.0001	3	Low
60**12*	6	1	8	No	No	No	0	392	1292	416	77%	0	0.0002	2	Low
60**12*	6	1	8	No	No	Yes	218	174	1292	416	90%	0	0.0001	3	Low

Note:

- 1-The asterisks (*) are where the product code invokes options such as alternative flange or thread options.
- 2- Where SIL 2 is declared in the tables, this is due to architecture constraints.



Product Safety Manual – Kinetro Actuator/Spring & Limit Switch Box

Arrangement one: Spring return mounted next to valve (valve not included); Actuator on valve; switch box mounted as noted either direct on the actuator or indirectly coupled – NOTE. This table provides the failure data when using the 'reversible spring return' concept captured in drawings 98-271 A1, and other similar drawings.

Kinetro Part	No. of Springs	No. of vanes	No. of vane bolts	Switch box included?	Switch Box Direct Mount	PVST? <i>(Partial valve stroke test)</i>	λ_{DD}	λ_{DU}	λ_S	$\lambda_{no\ effect}$	SFF	HFT	PFD _{AVG}	SIL	Demand Mode
							FITS	FITS	FITS	FITS	%				
03**1C*	1	1	2	Yes	Yes	No	0	28	811	3488	97%	0	0.0002	SIL 3	Low
03**1C*	1	1	2	Yes	Yes	Yes	19	16	804	3488	98%	0	0.0001	SIL 3	Low
03**1C*	1	1	2	No	No	No	0	28	703	3128	96%	0	0.0002	SIL 3	Low
03**1C*	1	1	2	No	No	Yes	19	16	696	3128	98%	0	0.0001	SIL 3	Low
05**1C*	1	1	2	Yes	Yes	No	0	28	811	3488	97%	0	0.0002	SIL 3	Low
05**1C*	1	1	2	Yes	Yes	Yes	19	16	804	3488	98%	0	0.0001	SIL 3	Low
05**1C*	1	1	2	No	No	No	0	28	703	3128	96%	0	0.0002	SIL 3	Low
05**1C*	1	1	2	No	No	Yes	19	16	696	3128	98%	0	0.0001	SIL 3	Low
07**1C*	1	1	4	Yes	Yes	No	0	31	814	3492	96%	0	0.0002	SIL 3	Low
07**1C*	1	1	4	Yes	Yes	Yes	23	18	805	3492	98%	0	0.0001	SIL 3	Low
07**1C*	1	1	4	No	No	No	0	31	706	3132	96%	0	0.0002	SIL 3	Low
07**1C*	1	1	4	No	No	Yes	23	18	697	3132	98%	0	0.0001	SIL 3	Low
08**1C*	1	1	4	Yes	Yes	No	0	31	814	3492	96%	0	0.0002	SIL 3	Low
08**1C*	1	1	4	Yes	Yes	Yes	23	18	805	3492	98%	0	0.0001	SIL 3	Low
08**1C*	1	1	4	No	No	No	0	31	706	3132	96%	0	0.0002	SIL 3	Low
08**1C*	1	1	4	No	No	Yes	23	18	697	3132	98%	0	0.0001	SIL 3	Low
09**1C*	1	1	4	Yes	Yes	No	0	31	814	3492	96%	0	0.0002	SIL 3	Low
09**1C*	1	1	4	Yes	Yes	Yes	23	18	805	3492	98%	0	0.0001	SIL 3	Low
09**1C*	1	1	4	No	No	No	0	31	706	3132	96%	0	0.0002	SIL 3	Low
09**1C*	1	1	4	No	No	Yes	23	18	697	3132	98%	0	0.0001	SIL 3	Low
10**1C*	1	1	4	Yes	Yes	No	0	31	814	3492	96%	0	0.0002	SIL 3	Low
10**1C*	1	1	4	Yes	Yes	Yes	23	18	805	3492	98%	0	0.0001	SIL 3	Low
10**1C*	1	1	4	No	No	No	0	31	706	3132	96%	0	0.0002	SIL 3	Low
10**1C*	1	1	4	No	No	Yes	23	18	697	3132	98%	0	0.0001	SIL 3	Low



Product Safety Manual – Kinetrol Actuator/Spring & Limit Switch Box

Arrangement two: No Spring return; Double Acting Actuator on valve; switch box mounted as noted either direct on the actuator or indirectly coupled; With and Without PVST; USING EXIDA DATA FOR AN Pneumatrol TYPE SOLENOID VALVE; AIR SUPPLY NOT INCLUDED; (Note that the Pneumatrol type solenoid valve is Kinetrol's preferred choice for this application)

Kinetrol Part	No. of Springs	No. of vanes	No. of vane bolts	Switch box included?	Switch Box Direct Mount	PVST? (Partial valve stroke test)	λ_{DD} FITS	λ_{DU} FITS	λ_S FITS	$\lambda_{no\ effect}$ FITS	SFF %	HFT	PFD _{AVG}	SIL	Demand Mode
02**10*	0	1	2	Yes	Yes	No	0	627	2277	616	78	0	0.003	2	Low
02**10*	0	1	2	Yes	Yes	Yes	373	254	2277	616	91	0	0.001	2	Low
02**10*	0	1	2	No	No	No	0	627	2172	254	78	0	0.003	2	Low
02**10*	0	1	2	No	No	Yes	373	253	2172	254	91	0	0.001	2	Low
03**10*	0	1	2	Yes	Yes	No	0	627	2277	616	78	0	0.003	2	Low
03**10*	0	1	2	Yes	Yes	Yes	373	254	2277	616	91	0	0.001	2	Low
03**10*	0	1	2	No	No	No	0	627	2172	254	78	0	0.003	2	Low
03**10*	0	1	2	No	No	Yes	373	253	2172	254	91	0	0.001	2	Low
05**10*	0	1	2	Yes	Yes	No	0	627	2277	616	78	0	0.003	2	Low
05**10*	0	1	2	Yes	Yes	Yes	373	254	2277	616	91	0	0.001	2	Low
05**10*	0	1	2	No	No	No	0	627	2172	254	78	0	0.003	2	Low
05**10*	0	1	2	No	No	Yes	373	253	2172	254	91	0	0.001	2	Low
07**10*	0	1	4	Yes	Yes	No	0	629	2284	622	78	0	0.003	2	Low
07**10*	0	1	4	Yes	Yes	Yes	373	256	2284	622	91	0	0.001	2	Low
07**10*	0	1	4	No	No	No	0	629	2176	262	78	0	0.003	2	Low
07**10*	0	1	4	No	No	Yes	373	256	2176	262	91	0	0.001	2	Low
08**10*	0	1	4	Yes	Yes	No	0	629	2284	622	78	0	0.003	2	Low
08**10*	0	1	4	Yes	Yes	Yes	373	256	2284	622	91	0	0.001	2	Low
08**10*	0	1	4	No	No	No	0	629	2176	262	78	0	0.003	2	Low
08**10*	0	1	4	No	No	Yes	373	256	2176	262	91	0	0.001	2	Low
09**10*	0	1	4	Yes	Yes	No	0	629	2284	622	78	0	0.003	2	Low
09**10*	0	1	4	Yes	Yes	Yes	373	256	2284	622	91	0	0.001	2	Low
09**10*	0	1	4	No	No	No	0	629	2176	262	78	0	0.003	2	Low
09**10*	0	1	4	No	No	Yes	373	256	2176	262	91	0	0.001	2	Low
10**10*	0	1	4	Yes	Yes	No	0	629	2284	622	78	0	0.003	2	Low
10**10*	0	1	4	Yes	Yes	Yes	373	256	2284	622	91	0	0.001	2	Low



Product Safety Manual – Kinetro Actuator/Spring & Limit Switch Box

Kinetro Part	No. of Springs	No. of vanes	No. of vane bolts	Switch box included?	Switch Box Direct Mount	PVST? (Partial valve stroke test)	λ_{DD} FITS	λ_{DU} FITS	λ_S FITS	$\lambda_{no\ effect}$ FITS	SFF %	HFT	PFD _{AVG}	SIL	Demand Mode
10**10*	0	1	4	No	No	No	0	629	2176	262	78	0	0.003	2	Low
10**10*	0	1	4	No	No	Yes	373	256	2176	262	91	0	0.001	2	Low
12**10*	0	1	6	Yes	Yes	No	0	632	2294	630	78	0	0.003	2	Low
12**10*	0	1	6	Yes	Yes	Yes	373	258	2290	630	91	0	0.001	2	Low
12**10*	0	1	6	No	No	No	0	632	2186	270	78	0	0.003	2	Low
12**10*	0	1	6	No	No	Yes	374	258	2186	270	91	0	0.001	2	Low
14**10*	0	1	8	Yes	Yes	No	0	635	2298	638	78	0	0.003	2	Low
14**10*	0	1	8	Yes	Yes	Yes	374	261	2298	638	91	0	0.001	2	Low
14**10*	0	1	8	No	No	No	0	635	2196	277	78	0	0.003	2	Low
14**10*	0	1	8	No	No	Yes	374	261	2196	277	91	0	0.001	2	Low
15**10*	0	1	8	Yes	Yes	No	0	635	2298	638	78	0	0.003	2	Low
15**10*	0	1	8	Yes	Yes	Yes	374	261	2298	638	91	0	0.001	2	Low
15**10*	0	1	8	No	No	No	0	635	2196	277	78	0	0.003	2	Low
15**10*	0	1	8	No	No	Yes	374	261	2196	277	91	0	0.001	2	Low
16**10*	0	1	8	Yes	Yes	No	0	635	2298	638	78	0	0.003	2	Low
16**10*	0	1	8	Yes	Yes	Yes	374	261	2298	638	91	0	0.001	2	Low
16**10*	0	1	8	No	No	No	0	635	2196	277	78	0	0.003	2	Low
16**10*	0	1	8	No	No	Yes	374	261	2196	277	91	0	0.001	2	Low
18**10*	0	1	8	Yes	Yes	No	0	635	2298	638	78	0	0.003	2	Low
18**10*	0	1	8	Yes	Yes	Yes	374	261	2298	638	91	0	0.001	2	Low
18**10*	0	1	8	No	No	No	0	635	2196	277	78	0	0.003	2	Low
18**10*	0	1	8	No	No	Yes	374	261	2196	277	91	0	0.001	2	Low
20**10*	0	2	8	Yes	Yes	No	0	731	2660	951	78	0	0.003	2	Low
20**10*	0	2	8	Yes	Yes	Yes	424	306	2259	951	91	0	0.001	2	Low
20**10*	0	2	8	No	No	No	0	730	2538	590	78	0	0.003	2	Low
20**10*	0	2	8	No	No	Yes	425	306	2538	590	91	0	0.001	2	Low
21**10*	0	1	8	Yes	Yes	No	0	635	2298	638	78	0	0.003	2	Low
21**10*	0	1	8	Yes	Yes	Yes	374	261	2298	638	91	0	0.001	2	Low
21**10*	0	1	8	No	No	No	0	635	2196	277	78	0	0.003	2	Low
21**10*	0	1	8	No	No	Yes	374	261	2196	277	91	0	0.001	2	Low



Product Safety Manual – Kinetro Actuator/Spring & Limit Switch Box

Kinetro Part	No. of Springs	No. of vanes	No. of vane bolts	Switch box included?	Switch Box Direct Mount	PVST? <i>(Partial valve stroke test)</i>	λ_{DD} FITS	λ_{DU} FITS	λ_S FITS	$\lambda_{no\ effect}$ FITS	SFF %	HFT	PFD _{AVG}	SIL	Demand Mode
30**10*	0	3	8	Yes	Yes	No	0	848	3016	1300	78	0	0.004	2	Low
30**10*	0	3	8	Yes	Yes	Yes	475	352	3016	1300	91	0	0.002	2	Low
30**10*	0	3	8	No	No	No	0	828	2908	937	78	0	0.004	2	Low
30**10*	0	3	8	No	No	Yes	476	352	2908	937	91	0	0.002	2	Low
40**10*	0	1	8	Yes	Yes	No	0	635	2298	638	78	0	0.003	2	Low
40**10*	0	1	8	Yes	Yes	Yes	374	261	2298	638	91	0	0.001	2	Low
40**10*	0	1	8	No	No	No	0	635	2196	277	78	0	0.003	2	Low
40**10*	0	1	8	No	No	Yes	374	261	2196	277	91	0	0.001	2	Low
60**10*	0	1	8	Yes	Yes	No	0	635	2298	638	78	0	0.003	2	Low
60**10*	0	1	8	Yes	Yes	Yes	374	261	2298	638	91	0	0.001	2	Low
60**10*	0	1	8	No	No	No	0	635	2196	277	78	0	0.003	2	Low
60**10*	0	1	8	No	No	Yes	374	261	2196	277	91	0	0.001	2	Low

Note: Where SIL 2 is declared in the tables, this is due to architecture constraints or PFD.



Product Safety Manual – Kinetro Actuator/Spring & Limit Switch Box

Arrangement three: No Spring return, Double Acting Actuator on valve, switch box mounted as indicated; With and Without PVST; PILOT SOLENOID OR AIR SUPPLY NOT INCLUDED

Kinetro Part	No. of Springs	No. of vanes	No. of vane bolts	Switch box included?	Switch Box Direct Mount	PVST? <i>(Partial valve stroke test)</i>	λ_{DD} FITS	λ_{DU} FITS	λ_S FITS	$\lambda_{no\ effect}$ FITS	SFF %	HFT	PFD _{AVG}	SIL	Demand Mode
02**10*	0	1	2	Yes	Yes	No	0	89	434	616	83	0	0.0004	2	Low
02**10*	0	1	2	Yes	Yes	Yes	50	39	434	616	93	0	0.0002	3	Low
02**10*	0	1	2	No	No	No	0	89	326	254	79	0	0.0004	2	Low
02**10*	0	1	2	No	No	Yes	50	38	326	254	91	0	0.0002	3	Low
03**10*	0	1	2	Yes	Yes	No	0	89	434	616	83	0	0.0004	2	Low
03**10*	0	1	2	Yes	Yes	Yes	50	39	434	616	93	0	0.0002	3	Low
03**10*	0	1	2	No	No	No	0	89	326	254	79	0	0.0004	2	Low
03**12*	0	1	2	No	No	Yes	50	38	326	254	91	0	0.0002	3	Low
05**10*	0	1	2	Yes	Yes	No	0	89	434	616	83	0	0.0004	2	Low
05**10*	0	1	2	Yes	Yes	Yes	50	39	434	616	93	0	0.0002	3	Low
05**10*	0	1	2	No	No	No	0	89	326	254	79	0	0.0004	2	Low
05**10*	0	1	2	No	No	Yes	50	38	326	254	91	0	0.0002	3	Low
07**10*	0	1	4	Yes	Yes	No	0	91	444	623	83	0	0.0004	2	Low
07**10*	0	1	4	Yes	Yes	Yes	51	41	444	623	93	0	0.0002	3	Low
07**10*	0	1	4	No	No	No	0	91	336	262	79	0	0.0004	2	Low
07**10*	0	1	4	No	No	Yes	51	41	336	262	90	0	0.0002	3	Low
08**10*	0	1	4	Yes	Yes	No	0	91	444	623	83	0	0.0004	2	Low
08**10*	0	1	4	Yes	Yes	Yes	51	41	444	623	93	0	0.0002	3	Low
08**10*	0	1	4	No	No	No	0	91	336	262	79	0	0.0004	2	Low
08**10*	0	1	4	No	No	Yes	51	41	336	262	90	0	0.0002	3	Low
09**10*	0	1	4	Yes	Yes	No	0	91	444	623	83	0	0.0004	2	Low
09**10*	0	1	4	Yes	Yes	Yes	51	41	444	623	93	0	0.0002	3	Low
09**10*	0	1	4	No	No	No	0	91	336	262	79	0	0.0004	2	Low
09**10*	0	1	4	No	No	Yes	51	41	336	262	90	0	0.0002	3	Low
10**10*	0	1	4	Yes	Yes	No	0	91	444	623	83	0	0.0004	2	Low
10**10*	0	1	4	Yes	Yes	Yes	51	41	444	623	93	0	0.0002	3	Low
10**10*	0	1	4	No	No	No	0	91	336	262	79	0	0.0004	2	Low



Product Safety Manual – Kinetro Actuator/Spring & Limit Switch Box

10**10*	0	1	4	No	No	Yes	51	41	336	262	90	0	0.0002	3	Low
12**10*	0	1	6	Yes	Yes	No	0	94	454	630	83	0	0.0004	2	Low
12**10*	0	1	6	Yes	Yes	Yes	51	43	450	630	92	0	0.0002	3	Low
12**10*	0	1	6	No	No	No	0	94	348	270	78	0	0.0004	2	Low
12**10*	0	1	6	No	No	Yes	51	43	348	270	90	0	0.0002	3	Low
14**10*	0	1	8	Yes	Yes	No	0	97	458	638	83	0	0.0004	2	Low
14**10*	0	1	8	Yes	Yes	Yes	51	46	458	638	92	0	0.0011	3	Low
14**10*	0	1	8	No	No	No	0	97	350	277	79	0	0.0004	2	Low
14**10*	0	1	8	No	No	Yes	51	46	350	277	90	0	0.0002	3	Low
15**10*	0	1	8	Yes	Yes	No	0	97	458	638	83	0	0.0004	2	Low
15**10*	0	1	8	Yes	Yes	Yes	51	46	458	638	92	0	0.0011	3	Low
15**10*	0	1	8	No	No	No	0	97	350	277	79	0	0.0004	2	Low
15**10*	0	1	8	No	No	Yes	51	46	350	277	90	0	0.0002	3	Low
16**10*	0	1	8	Yes	Yes	No	0	97	458	638	83	0	0.0004	2	Low
16**10*	0	1	8	Yes	Yes	Yes	51	46	458	638	92	0	0.0002	3	Low
16**10*	0	1	8	No	No	No	0	97	350	277	78	0	0.0004	2	Low
16**10*	0	1	8	No	No	Yes	51	46	350	277	90	0	0.0002	3	Low
18**10*	0	1	8	Yes	Yes	No	0	97	458	638	83	0	0.0004	2	Low
18**10*	0	1	8	Yes	Yes	Yes	51	46	458	638	92	0	0.0002	3	Low
18**10*	0	1	8	No	No	No	0	97	458	277	78	0	0.0004	2	Low
18**10*	0	1	8	No	No	Yes	51	46	350	277	90	0	0.0002	3	Low
20**10*	0	2	8	Yes	Yes	No	0	193	820	951	81	0	0.0008	2	Low
20**10*	0	2	8	Yes	Yes	Yes	102	91	819	951	91	0	0.0004	3	Low
20**10*	0	2	8	No	No	No	0	193	694	590	78	0	0.0008	2	Low
20**10*	0	2	8	No	No	Yes	102	91	698	590	90	0	0.0004	3	Low
21**10*	0	1	8	Yes	Yes	No	0	97	458	638	83	0	0.0004	2	Low
21**10*	0	1	8	Yes	Yes	Yes	51	46	458	638	92	0	0.0002	3	Low
21**10*	0	1	8	No	No	No	0	97	458	277	78	0	0.0004	2	Low
21**10*	0	1	8	No	No	Yes	51	46	350	277	90	0	0.0002	3	Low
30**10*	0	3	8	Yes	Yes	No	0	311	1176	1300	79	0	0.0014	2	Low
30**10*	0	3	8	Yes	Yes	Yes	153	137	1176	1300	91	0	0.0006	3	Low
30**10*	0	3	8	No	No	No	0	290	1068	939	79	0	0.0013	2	Low
30**10*	0	3	8	No	No	Yes	153	137	1068	939	90	0	0.0006	3	Low
40**10*	0	1	8	Yes	Yes	No	0	97	458	638	83	0	0.0004	2	Low
40**10*	0	1	8	Yes	Yes	Yes	51	46	458	638	92	0	0.0011	3	Low
40**10*	0	1	8	No	No	No	0	97	350	277	79	0	0.0004	2	Low
40**10*	0	1	8	No	No	Yes	51	46	350	277	90	0	0.0002	3	Low
60**10*	0	1	8	Yes	Yes	No	0	97	458	638	83	0	0.0004	2	Low
60**10*	0	1	8	Yes	Yes	Yes	51	46	458	638	92	0	0.0011	3	Low
60**10*	0	1	8	No	No	No	0	97	350	277	79	0	0.0004	2	Low
60**10*	0	1	8	No	No	Yes	51	46	350	277	90	0	0.0002	3	Low