



# Installation, Operation & Maintenance Instructions

## 054/057 Fire Fail-safe Unit

**FOR USE WITH THE FOLLOWING MODELS:**

**05++0\*0 – 1201**

KEY: ++ Will be one of the following:

- 4 - = Male Drive
- 3F = Female Drive
- 7 - = American Male Drive
- 7F = ANSI Female Drive
- 3S = Serrated Female Drive
- 7S = ANSI Serrated Female Drive

\*Will be one of the following:

- 2 = Clockwise spring action
- 3 = Anticlockwise spring action

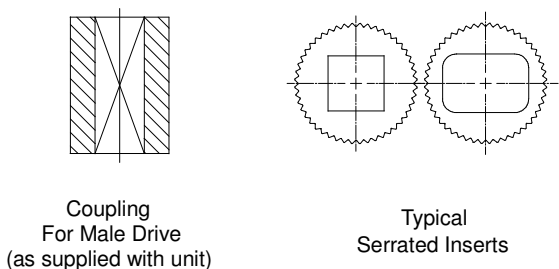
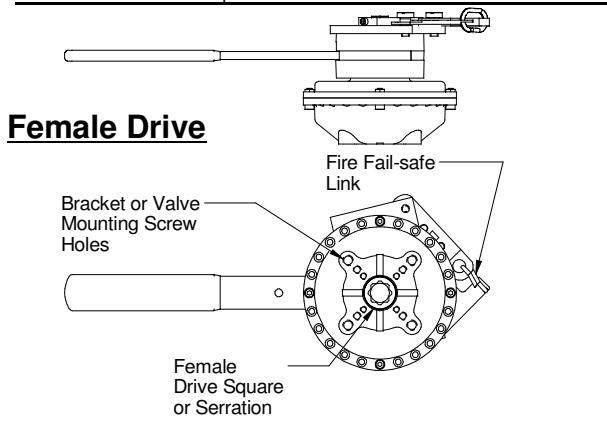
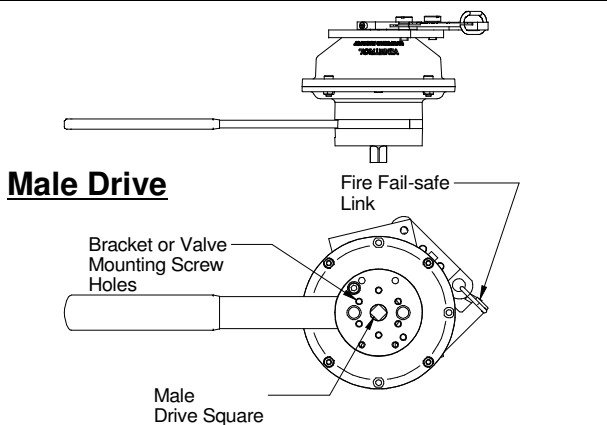

### 1.) INSTALLATION

- 1.1) Fit unit to bracket/valve with coupling to valve stem (unless a female drive version is used which can be directly connected to valve).
- 1.2) Ensure that coupling (if fitted) can be moved without much effort, such that it does not side load valve stem or manual handle shaft.
- 1.3) Refer to Kinetrol TD111 for recommended screw tightening torques.
- 1.4) Ensure that the handle is fitted in the orientation which allows the safe operation from a stable operating position.
- 1.5) If serrated drive is used – use a Kinetrol insert to provide drive to valve.

### 2.) OPERATION

- 2.1) Operating conditions:
  - Angle of travel 90° (Non-Adjustable)
  - Max vibrating conditions: 4g@100Hz
  - Ambient temperature range:-40°C to 80°C
- 2.2) Ensure that the handle is operated whilst standing in a stable position.

- 2.3) Rotate handle slowly with a good grip and ensure that there is nothing in the path of an accidentally released lever. Hook the Fire Fail-safe link over the groove in the L shaped lever and release the wrench and remove from square.
- 2.4) The link is now primed. To remove the link tension, follow this procedure in reverse.

### 3) MAINTENANCE

- 3.1) The Fire Fail-safe link can be replaced by removing the link tension (as described in 2.4) and removing the pivot pin. A suitable replacement can be obtained from Kinetrol. Quote serial number as printed on spring label.
- 3.2) The spring unit does not contain user serviceable components. If the spring is faulty it should be disposed of safely and replaced with a new unit or returned to Kinetrol for repair.