

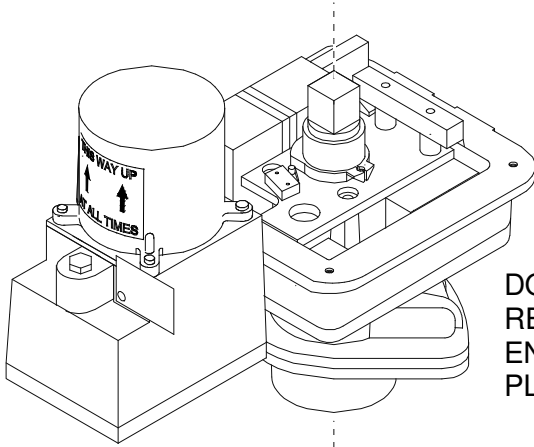

Installation, Operation & Maintenance Instructions - EHD Electrohydraulic 1/4 Turn Actuators

BASIC SPRING RETURN EHD
WITH CONTROL BOX LID REMOVED.
PUMP SET FOR VERTICAL AXIS (V)

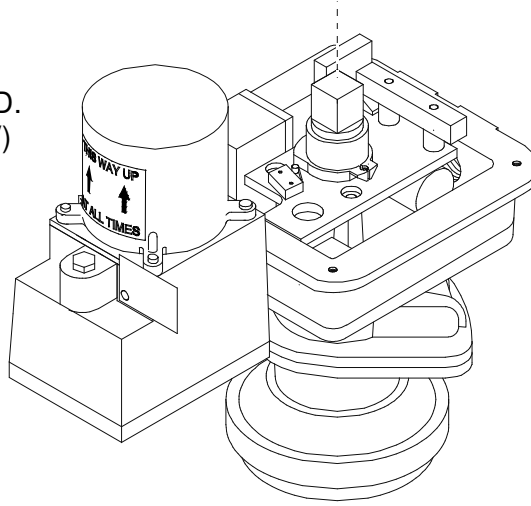

DOUBLE ACTING
RELAY CIRCUIT
ENCLOSED IN
PLASTIC BOX

BASIC DOUBLE ACTING EHD
WITH CONTROL BOX LID REMOVED.
PUMP SET FOR VERTICAL AXIS (V)

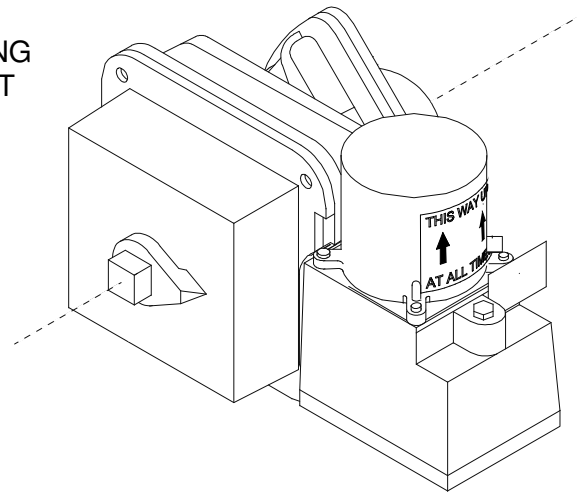

**NOTE: KEEP UNIT ORIENTED WITH
MOTOR AT THE TOP AT ALL TIMES TO
PREVENT OIL LOSS.**

DOUBLE ACTING EHD WITH
CONTROL BOX LID IN PLACE.
PUMP SET FOR HORIZONTAL AXIS (H)

CONTENTS

Page 1	Contents
Page 2	Transport, Storage and Preparation for use
Page 3	Exploded view of basic assembly
Page 4	Wiring connections - General notes and detail for SR On/off models
Page 5	Wiring connections for DA On/off models
Page 6	Wiring connections for Positioner models
Page 7	Wiring connections for direct switched SR models
Page 8	Limit switch adjustment
Page 9	Fuses and internal connections
Page 10	Optional Positioner set-up
Page 11	Optional angle transducer
Page 12	Optional double acting manual bypass valves
Page 13	Optional rapid spring return dump valve
Page 14	Optional external feedback potentiometer (on/off models only)
Page 15	Inspection, maintenance and troubleshooting



Preparation for use

NOTE : During transport and storage ensure that unit pump body is orientated in the direction of intended use.

Key to exploded diagram on page 3

1 – Pump/reservoir unit.	8 – Limit switch plate.	14 – External connector block.
2 – Vent plug.	9 – Fuse board mount assembly.	15 – Connector number plate.
3 – Filler plug.	10 – Limit switch.	16 – Connector block support pillars.
4 – Pump motor.	11 – Limit switch striker.	17 – Motor capacitor.
5 – Control box body.	12 – Control box lid.	18 – Limit switch mounting pillars.
6 – Solenoid valve.	13 – External indicator.	19 – Spring return vane actuator.
7 – Limit switch shaft.		

Numbers in brackets refer to the exploded diagram on page 3.

Before mounting the actuator, check that pump/reservoir orientation is correct.

The EHD actuator can be used with its output axis oriented vertically (V) or horizontally (H) – see page 1 for illustrations of these two options. The pump/reservoir unit (1), however, must be oriented with the motor (4) above the pump (1), and the actuator should have been ordered with the interface assembled to suit the user's application. The pump can be rotated through 90° to change the orientation between (V) and (H) to suit a different axis requirement.

In order to rotate the pump-to-control box interface, carry out the following steps:

1. Read through the following procedure and assemble the necessary tools, tubes, containers etc.
2. Support the whole actuator with the pump filler pointing upwards.
3. Unscrew the filler plug (3) – put both it and its sealing ring somewhere safe ready to be re-used later.
4. Drain the oil from the reservoir (1) into a clean container about 500ml (1 pint) in capacity. Syphoning with a U-shaped plastic tube works well here – start the flow by sucking with a squeeze bottle. About 270ml of oil should come out. Don't lose any oil, because you need to pour it back in again later.
5. Remove the external indicator (13) and the control box lid (12).
6. Remove the four M6 socket head screws holding the pump (1) to the control box (5). As these screws are loosened, support the pump body and don't let it move much relative to the control box flange, because the wires to the pump motor pass through the middle of this interface, and will be damaged or sheared off if much movement occurs. A small amount of oil may drop from the interface at this point.
7. Rotate the pump relative to the control box as required – again, take care not to damage or shear off the wires through the middle during this process. Refit the M6 screws and tighten in place.
8. Rotate the whole actuator so that the filler hole again points upwards, and support it in this position.
9. Pour back the oil and replace the filler plug plus the sealing ring – note that the sealing ring is vital to keep dust and water out of the reservoir.

ABSOLUTE CLEANLINESS OF OIL IS ESSENTIAL FOR RELIABLE PERFORMANCE.

IF ANY EXTRA OIL IS ADDED AT ANY TIME IN THE ACTUATOR'S LIFE, USE ONLY 50cSt SILICONE FLUID – UNLESS PURCHASED AS A SILICONE FREE UNIT IN WHICH CASE USE ENERGOL OIL HLP-HM32. These fluids are available from Kinetrol.

AFTER mounting the actuator, but BEFORE running it, pull out the vent plug (2). The vent plug is fitted only to prevent loss of fluid while the actuator is in transit – once the actuator is in its fixed position, this plug must be removed. If the vent plug is left in during extended running, thermal expansion and contraction of the fluid can damage the actuator.



Exploded Diagram – Base SR Model

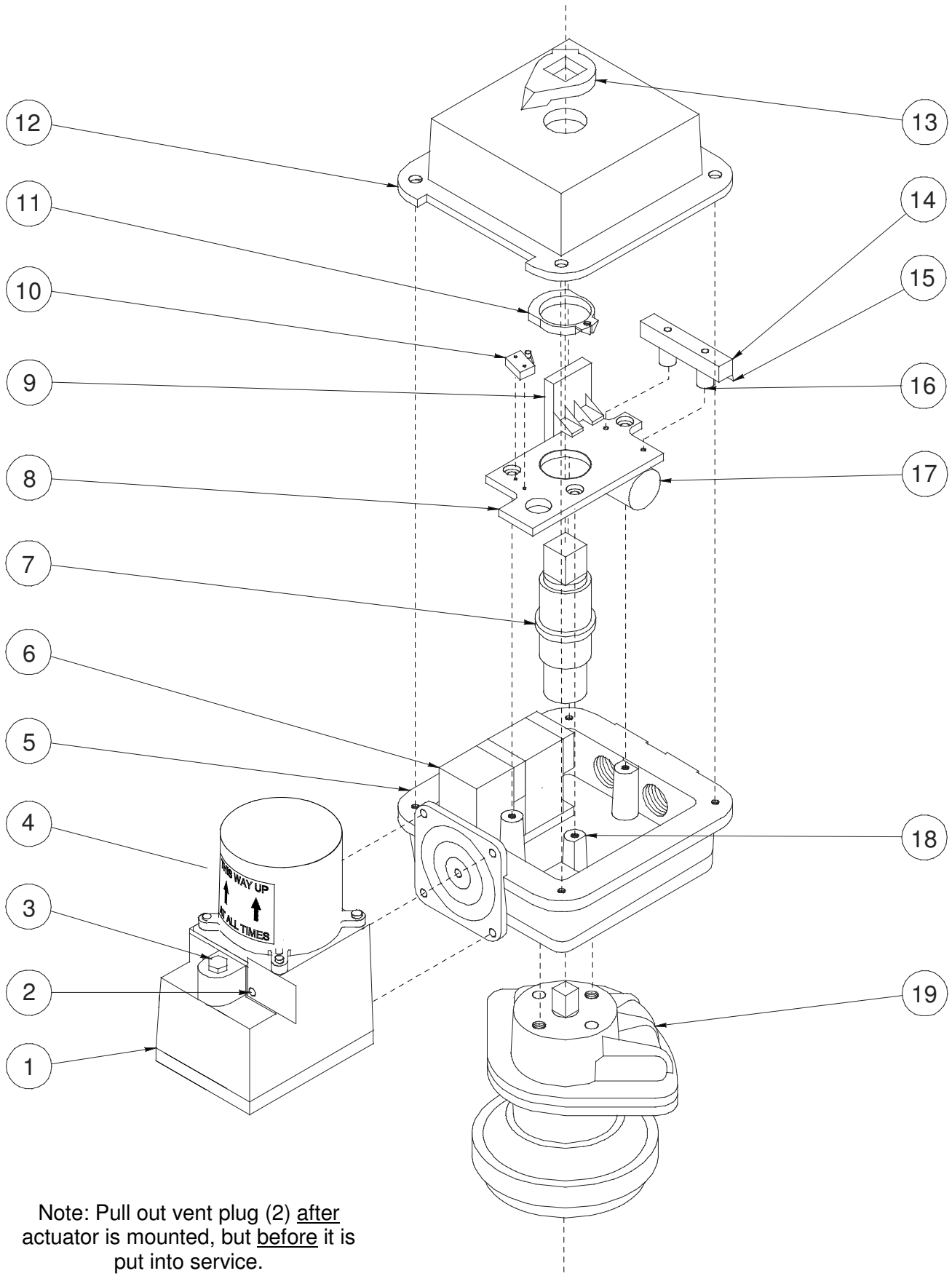

Note: Pull out vent plug (2) after actuator is mounted, but before it is put into service.



External Wiring Connections

WIRING CONNECTIONS – ALL MODELS

Wiring conduits with the required degree of environmental protection should be connected to the threaded conduit entry holes in the actuator control box. If the signal port is not being used, then it must be blocked using the plug supplied with all units except positioner models.

Access to the connector block is obtained by removing the external indicator and the control box lid, which is held on by four M4 slot headed screws.

BEFORE REMOVAL OF THE LID, ENSURE THAT POWER HAS BEEN DISCONNECTED

When wiring is complete, examine the sealing flange face of the control box to make sure no wires (either internal or external) can become trapped when the lid is replaced, and also make sure that the O ring is properly positioned in it's groove.

Spring Return On/Off EHD Wiring Connections
Top View of Control Box with Lid Off

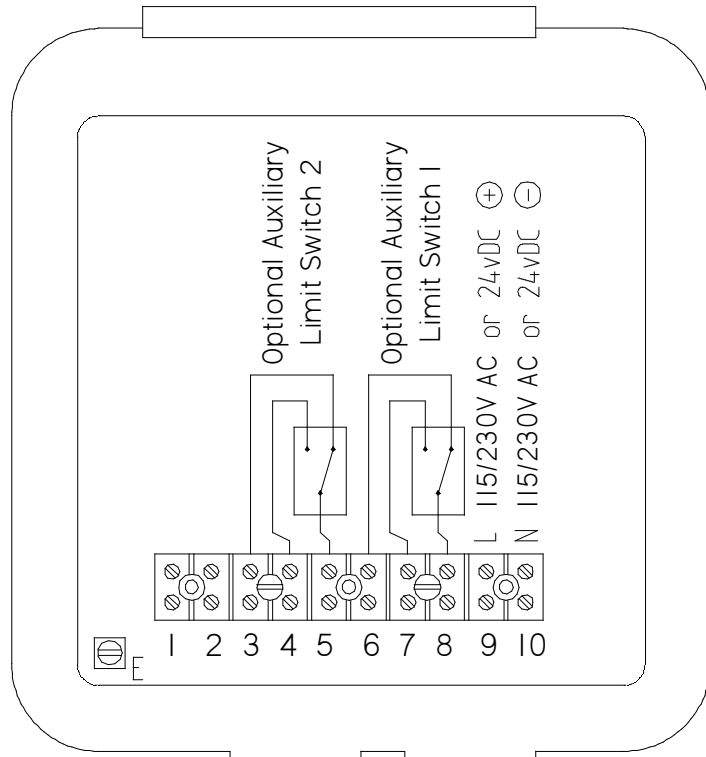

Signal Conduit Entry Power Conduit Entry

IMPORTANT

The terminal fixed to the control box casting, labelled "E" on the diagram, must be connected to an earth or ground line.

All live supply lines, labelled "L" on the diagram, must be fitted with 2A fuses external to the EHD Actuator.

All EHD models fall into one of four groups for wiring purposes:

- (1) Spring Return On/Off
- (2) Double Acting On/Off
- (3) Positioners
- (4) Direct Switched SR

Diagrams showing external wiring connector identities for these groups follow on pages 4 to 7.



Wiring Connections – DA On/Off Models

Double Acting On/Off EHD Wiring Connections
Top View of Control Box with Lid Off

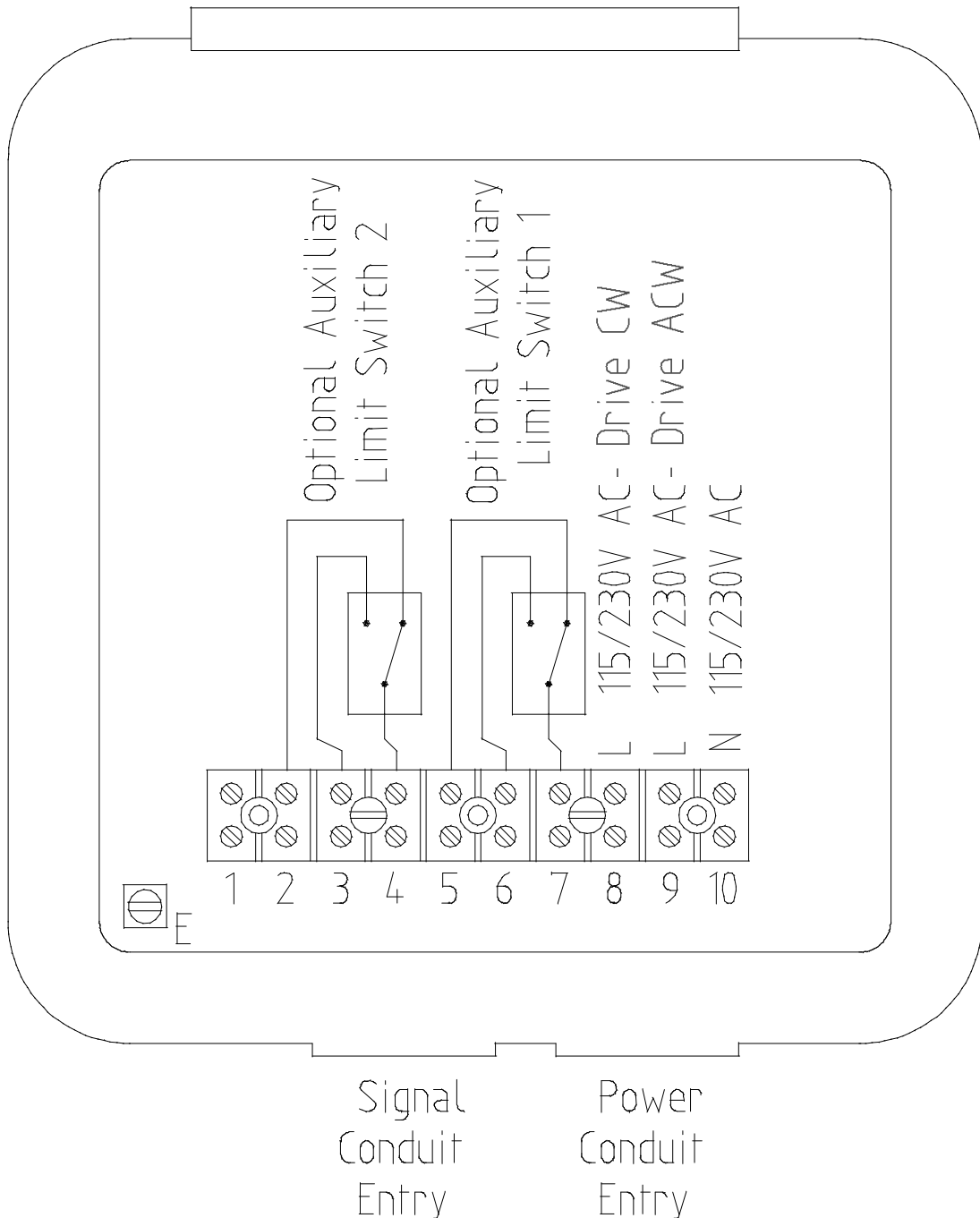



Wiring Connections – Positioner Models

Positioner EHD Wiring Connections Top View of Control Box with Lid Off

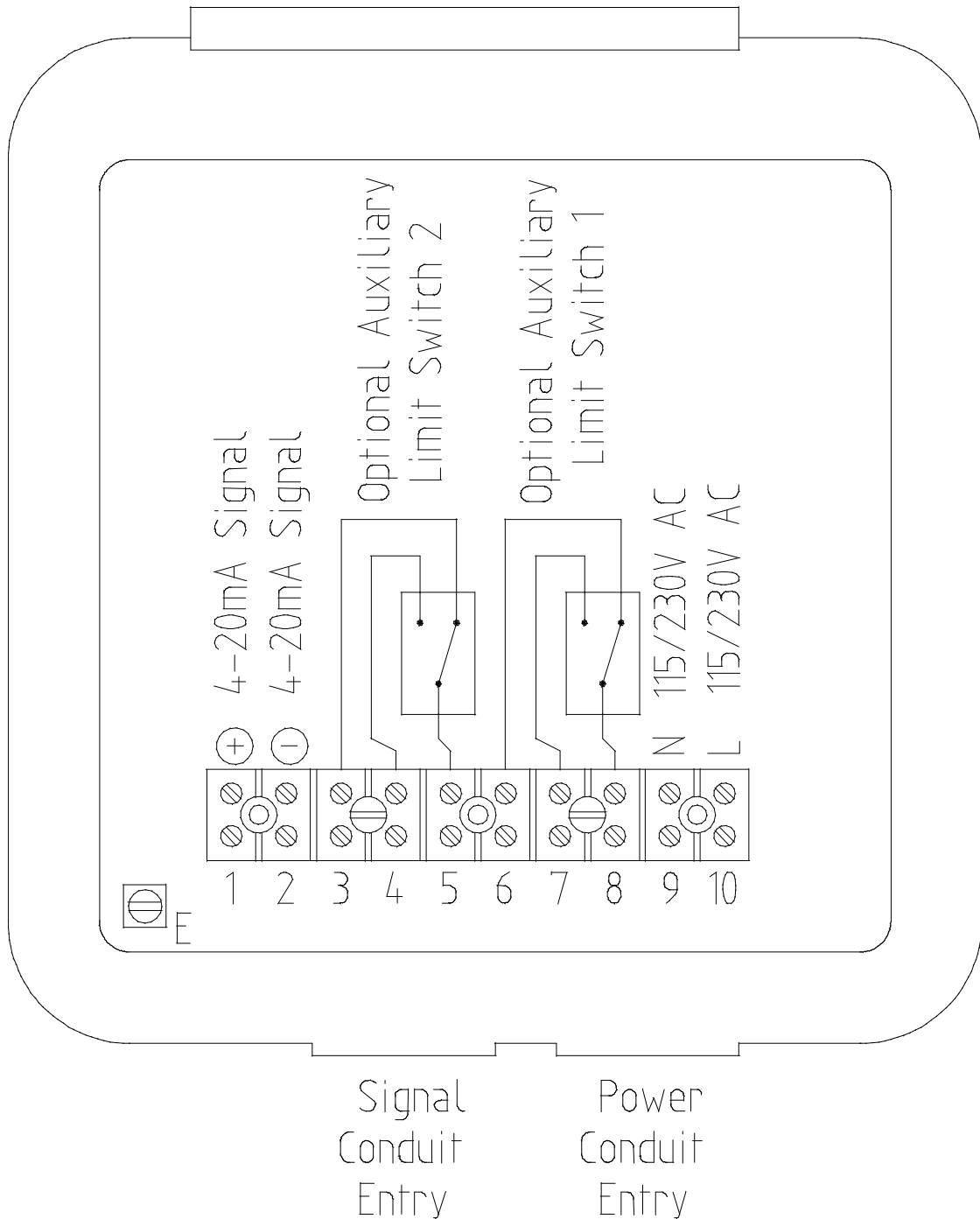



Wiring Connections – Direct Switched Spring Return Models

Direct Switched Spring Return EHD Wiring Connections

Top View of Control Box with Lid Off

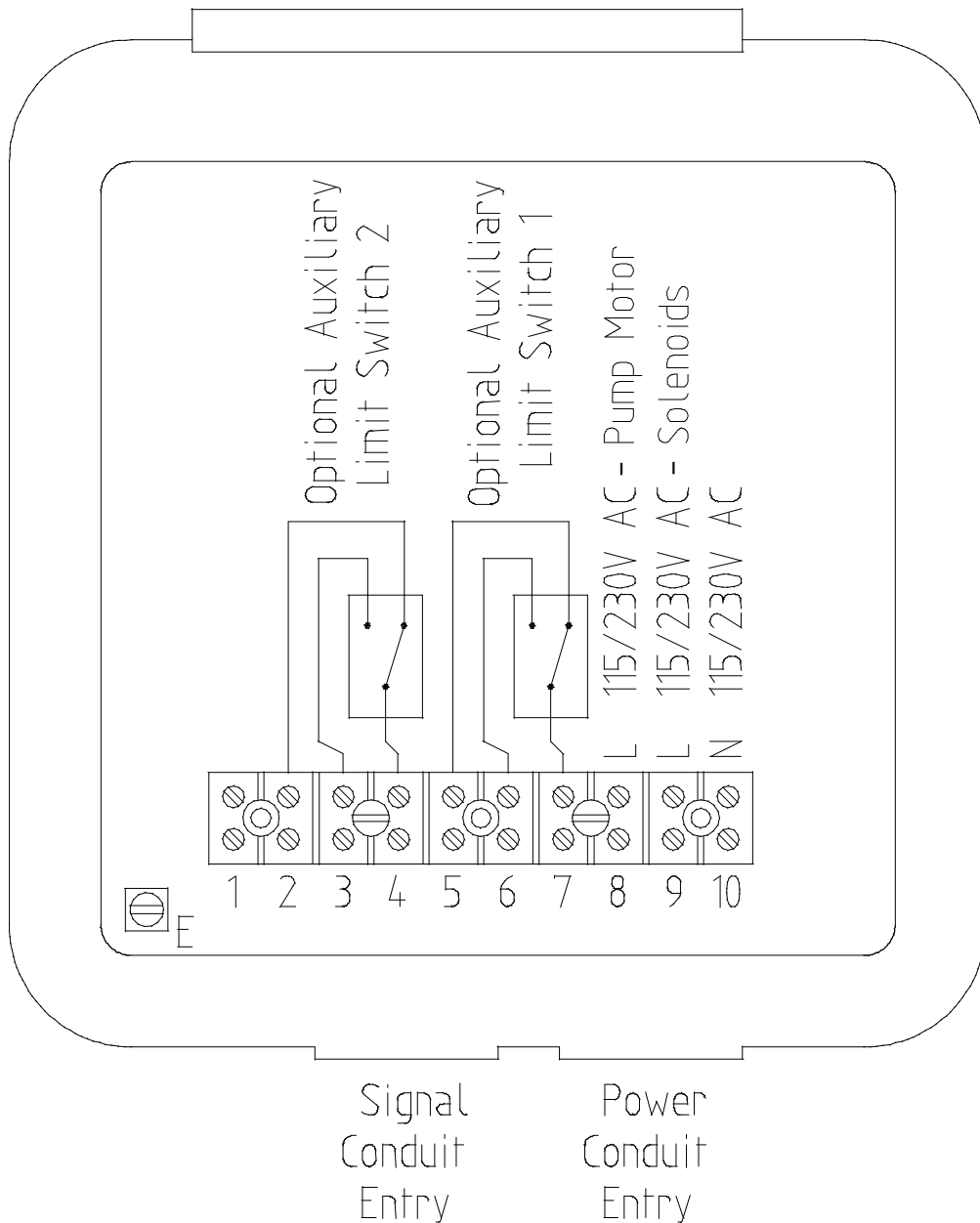



Limit Switch Adjustment

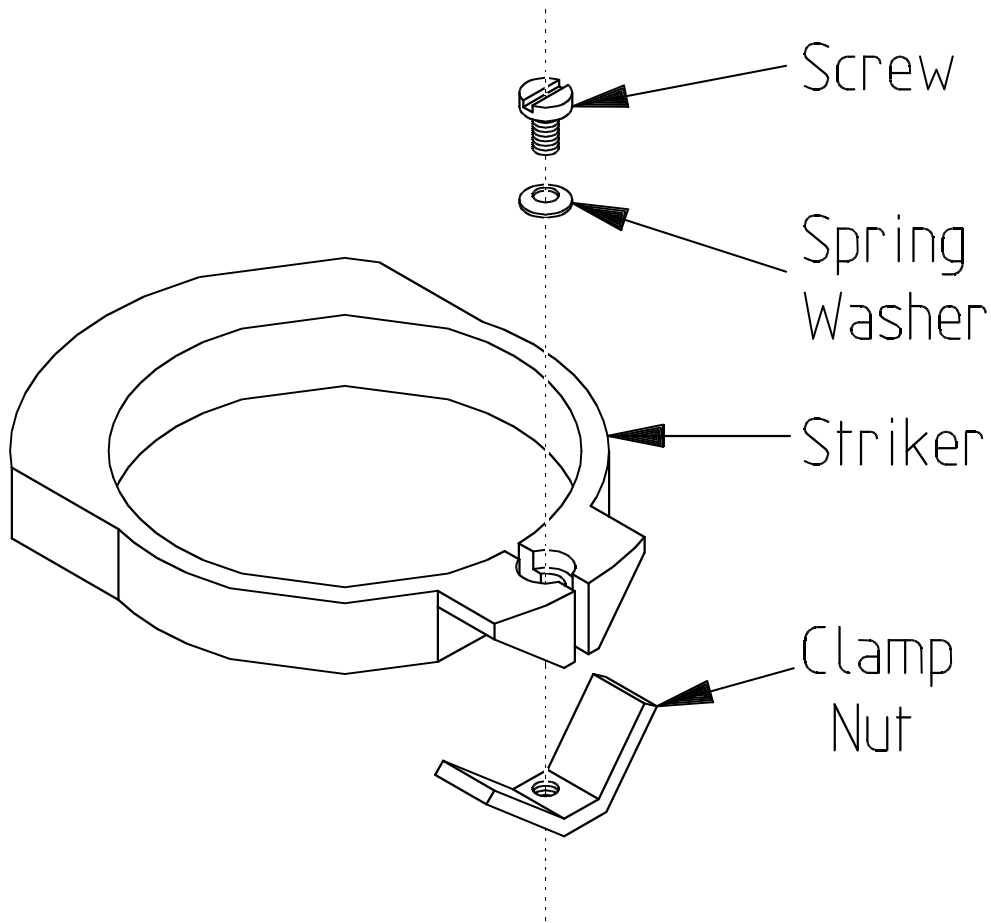

Limit Switch Striker Assembly

Disconnect power before adjusting limit switch strikers.

The one or two limit switches at the bottom of the stack (one for spring return units, two for double acting units) are the actuator travel limit switches, with strikers factory-set to stop the actuator just before the actuator's mechanical end-stop is reached. These switches can be adjusted by the user to limit travel as required – however, care should be taken to avoid leaving the actuator motor driving against its own end-stop, or against the load's travel limit.

Any further limit switches are optional auxiliary switches to allow the user to signal position as required.

The bottom switch should be adjusted first, then the next one up, etc., so that for each one the clamp screw is not obscured by a cam which has already been set.

To set a cam, first slacken its clamp screw using a slot headed screwdriver, without completely undoing it and letting the clamp nut drop off underneath. Rotate the cam into position on the shaft, and re-tighten the clamp screw.



Fuses and Internal Connections

Fuses – 20mm Quick blow Type 2A
 Held in plastic insert – to remove pull
 towards you on this view
 Function of fuse depends on model as
 follows:

MODEL	FUSE 1	FUSE 2
SR ON/OFF	In use	Spare
DA ON/OFF	In use C/W	In use AC/W
SR POS'NER	Spare	In use
DA POS'NER	In use	Spare
DIRECT SW.	In use pump	In use Sols.

- 1 – N Sol 1 – Blue
- 2 – L Sol 1 – Brown
- 3 – N Sol 2 – Blue
- 4 – L Sol 2 – Brown
- 5 – N Motor – Blue
- 6 – L Motor – Brown
- 7 – Cap Phase Motor - White

Note: On SR models only one
 solenoid valve is normally fitted:
 SOL 1 for C/W spring units
 SOL 2 for AC/W spring units

SIDE VIEW OF EHD
 CONTROL BOX, SHOWING
 FUSE BOARD, SOLENOID
 VALVES, AND INTERNAL
 WIRE IDENTITIES.

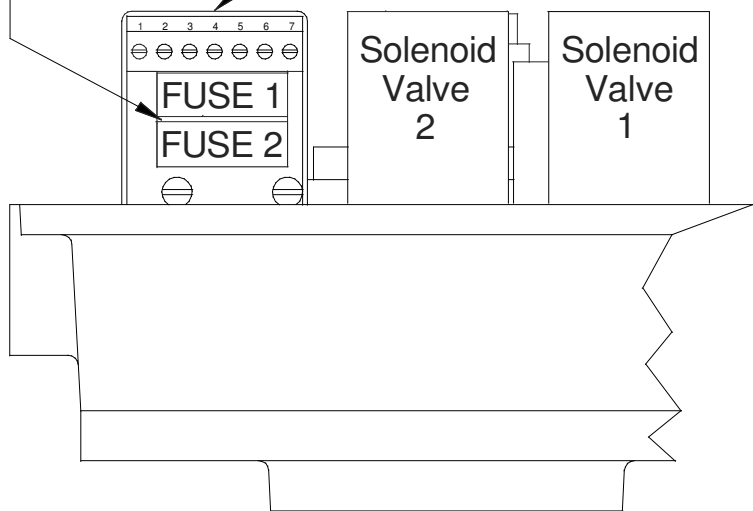

All internal wiring on an EHD actuator is connected via the fuse board. Wires to the solenoid valves and the pump motor connect to the accessible upper row of connectors shown in the diagram above. All the other wiring, connecting to the lower two rows of connectors, will come out as part of the limit switch plate assembly when it is removed, since it connects only to parts mounted on the limit switch plate.

The fuse board also contains Metal Oxide Varistor suppressor devices, which will act to blow the fuse(s) if the supply voltage rises to a level which may damage the actuator components.

The fuses are mounted as shown in the diagram above. On some models (positioners and on/off spring return types) where only one live supply is connected, only one fuse is needed, and so the second fuse can be used as a spare.

DISCONNECT SUPPLY BEFORE REMOVING OR REPLACING FUSEHOLDER



Optional Positioner - Setup

The positioner circuit is mounted inside a moulded plastic box, which in turn is mounted together with the position feedback potentiometer and drive strap on the limit switch plate inside the control box. The unit is factory-adjusted to give 90 degree movement as the signal is changed from 4 to 20mA. Zero-adjust and gain-adjust preset potentiometers are available to allow tuning of start position and range, to fit a user's exact requirements (see below). A deadband-adjust preset potentiometer is also available to maximise accuracy in a particular application.

When the actuator is in operation with its load, it is recommended that the deadband adjustment is altered until the actuator begins to oscillate in position (i.e. switches on and off in alternating directions) – then the deadband adjustment should be altered slightly until the actuator is stable in position – this will give maximum accuracy.

Take care not to connect the power supply to the signal input connector.

See page 6 for identity of connector terminals. If a positioner limit switch plate is being fitted to a control box, make sure you know which end of its travel the actuator is at, and hold the shaft and its following pot assembly at the corresponding end of its travel – a mistake here will result in a damaged pot and drive assembly.

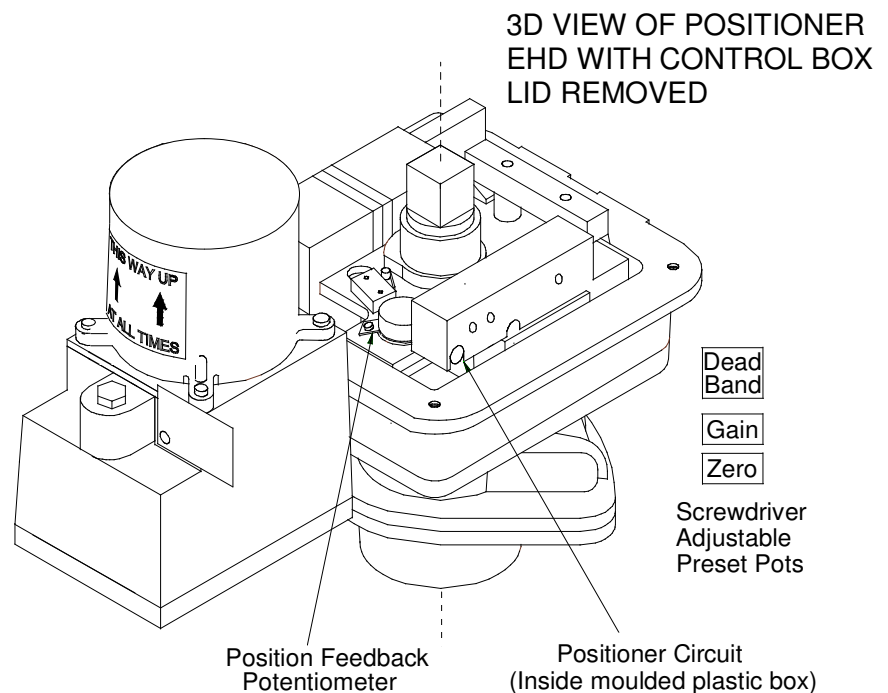
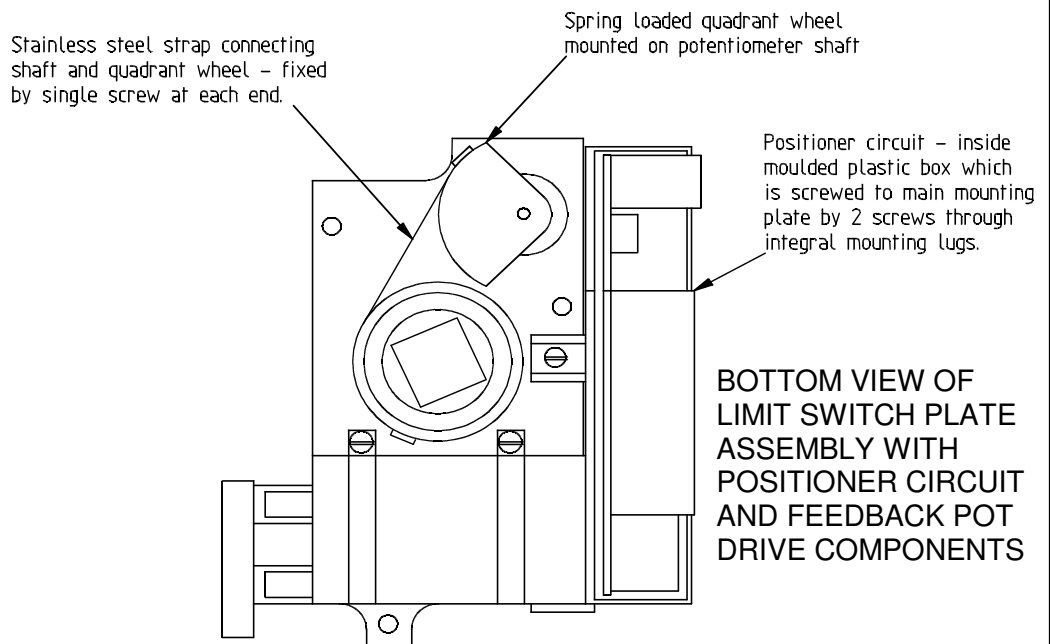



Optional Angle Transducer

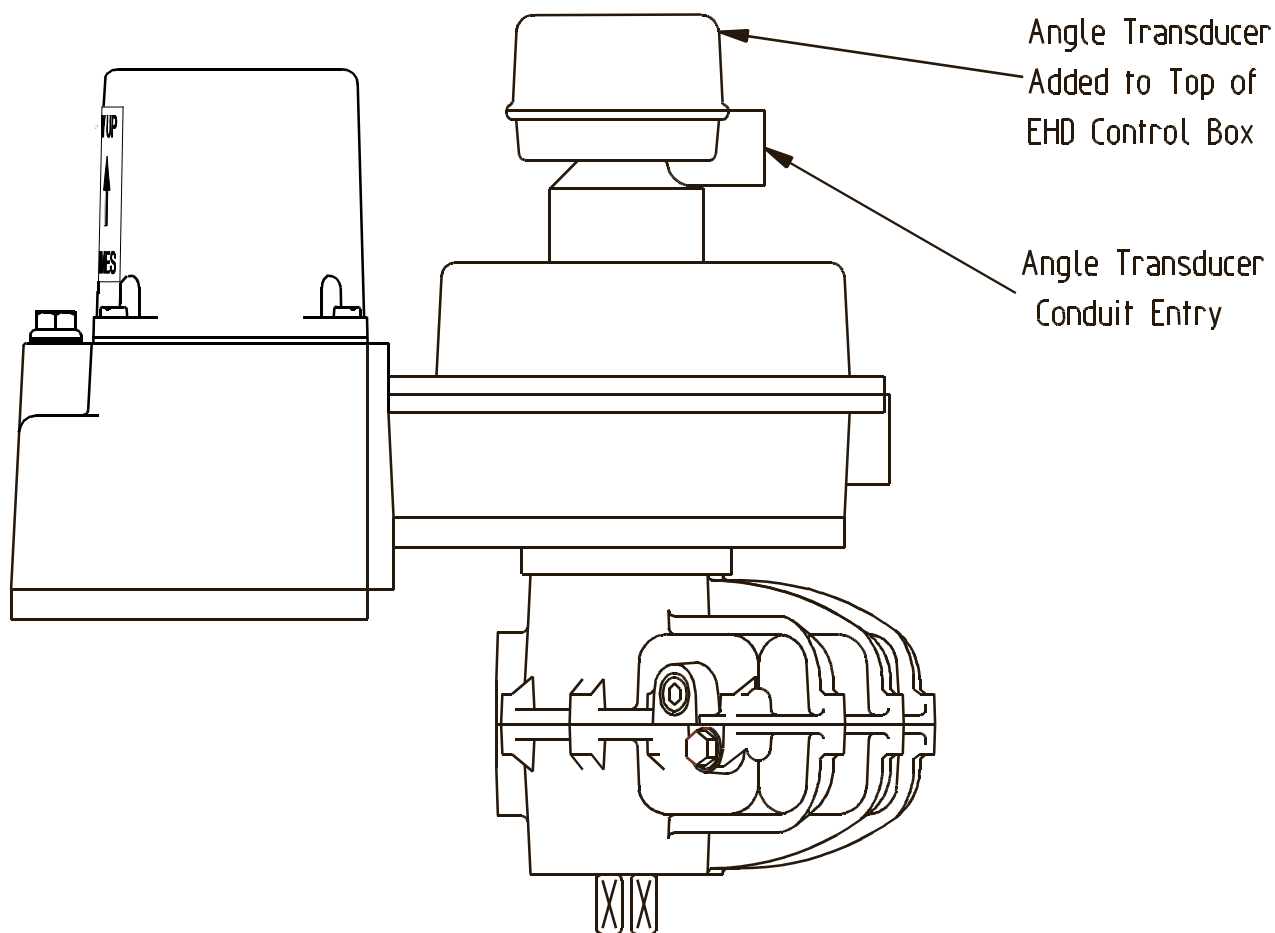

SIDE VIEW OF EHD ASSEMBLY WITH ANGLE TRANSDUCER UNIT FITTED

The standard Kinetrol angle transducer unit is bolted to a modified EHD lid to give an entirely independent position feedback signal to the user, which in no way depends on either the potentiometer or the electronic circuit of the positioner in the EHD.

External visual position indication is no longer possible because the output square is covered by the angle transducer mounting parts.

See the attached angle transducer instruction sheet TD5 for connection and adjustment of angle transducer.



Optional Double Acting Manual Bypass Valve

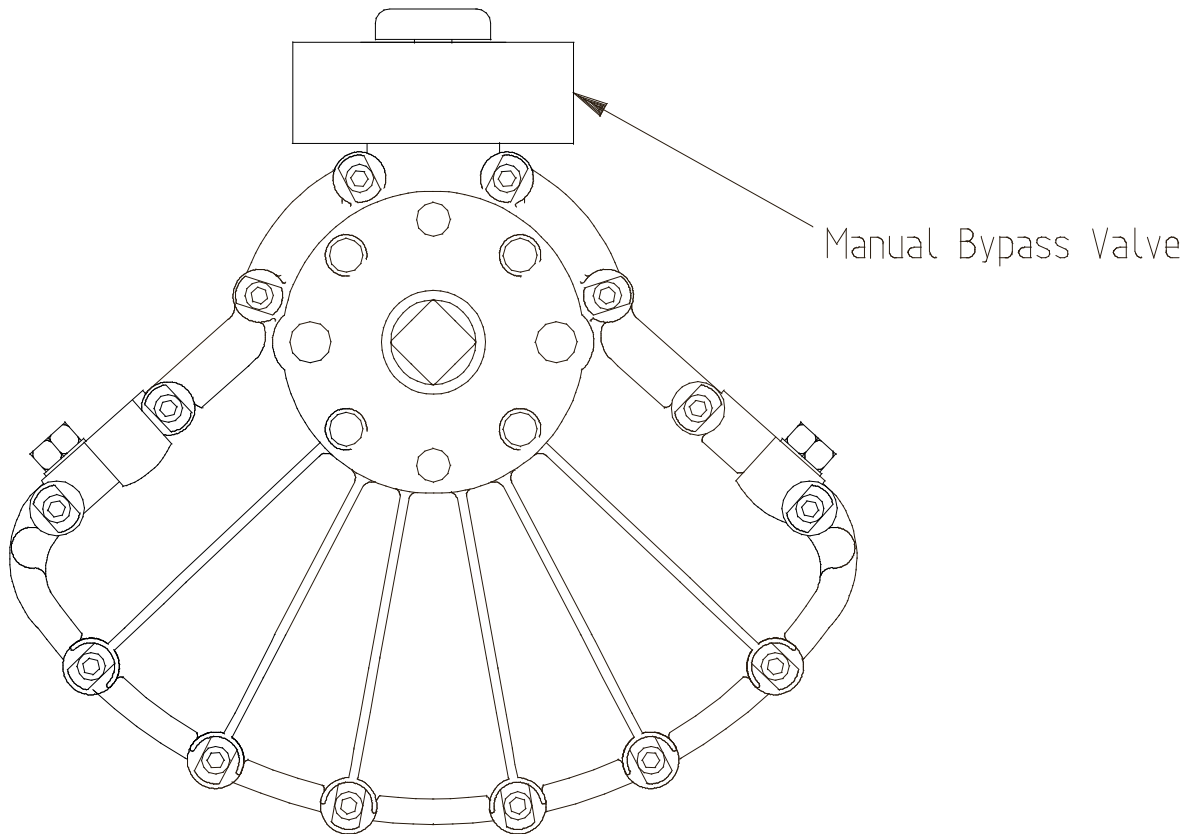

VANE ACTUATOR WITH INTEGRAL MANUAL BYPASS VALVE FITTED FOR EHD USE

The manual bypass valve is a plug type valve mounted directly on the vane actuator, allowing an operator to open an oil port between the two sides of the actuator, which in turn allows a fail-locked double acting actuator to be manually over-ridden when the power supply has failed. The valve is opened by turning the selector to the open position as indicated by the label. For normal powered actuator operation it is necessary that the valve be left closed, so that full operating pressure can be developed in the actuator – the valve is closed by turning the selector to the shut position.

The oil ports to this valve are narrow, so it will not be possible to move the actuator by manual over-ride at a speed much greater than its normal operating speed (see sales literature at the end of this document) – trying to move it too fast may generate excessive pressures and forces which can damage the actuator.



Optional Solenoid Operated Rapid Spring Return Dump Valve

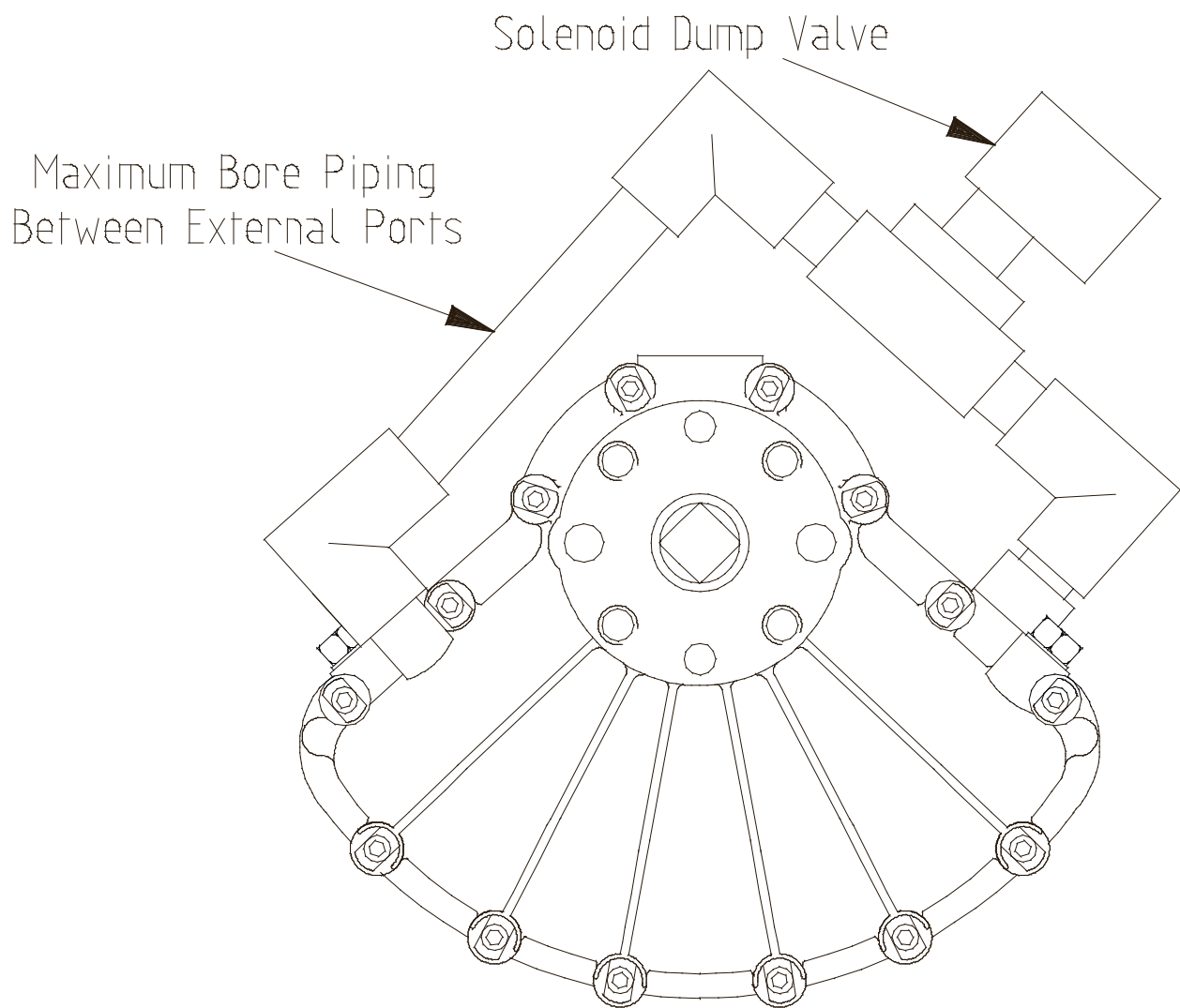

VANE ACTUATOR WITH SOLENOID
OPERATED RAPID DUMP VALVE FOR
USE WITH SPRING RETURN EHD.

A large capacity 2/2 solenoid valve is piped to the two external actuator ports using the widest bore tube and fittings compatible with the ports. It is additional to the normal internal EHD solenoid valves, and does not prevent them working. Wiring connection of the dump valve is left to the user, since there are several functions possible, all requiring different arrangements. The standard coil has a DIN 43650 3-pin interface.



Optional External Feedback Potentiometer

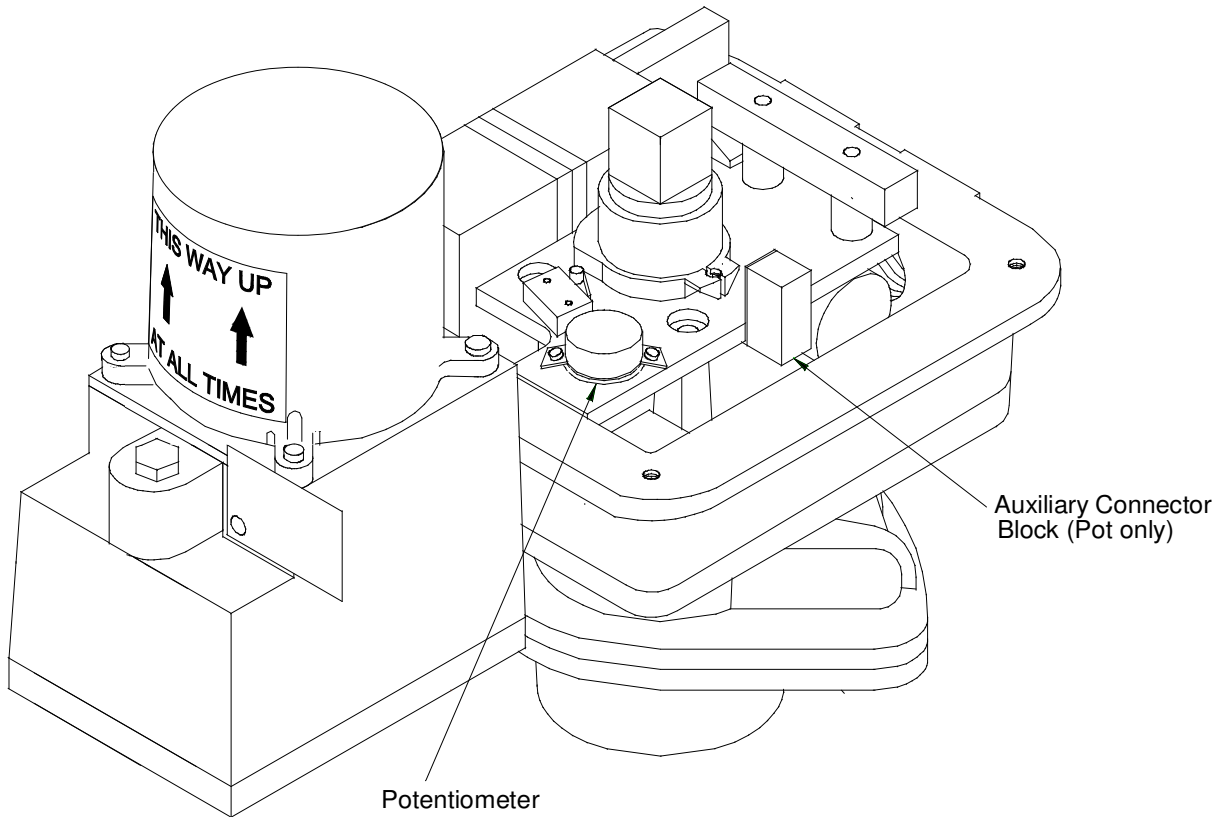

3D VIEW OF ON/OFF EHD ACTUATOR
WITH EXTERNAL FEEDBACK POT.

A 20K conductive plastic servo potentiometer (with dual ball bearings and laser trimmed track giving linearity better than 1.0% of full scale range) is fitted to the standard limit switch plate, and driven by a spring tensioned stainless steel strap attached to the limit switch shaft. The pot gives its full range over 340 degrees, so this application uses about 30% of its track. Three wires connect the two ends of the pot track plus its wiper to three terminals in an auxiliary connector block mounted to one side of the limit switch plate. External connections should be made to this terminal block.



Inspection, Maintenance and Troubleshooting

Inspection and Maintenance

For reliable long term operation, it is recommended that the following inspection procedure is carried out at least once per year, and the recommended actions taken if necessary.

1. Observe a complete operating cycle of the actuator, and if it fails to operate correctly as detailed here then see the troubleshooting guide below for recommended remedial actions. When power is switched on, the actuator should run smoothly through 90 degrees. At the end of its travel, the limit switch should cut out the pump. In the case of a spring return, after the pump cuts out the unit should hold position without dropping back as long as power is on, and when power is switched off the spring stroke should be smooth and not too slow.
2. Disconnect power from the actuator, remove the position indicator, then remove the control box lid.
3. Remove the oil filler plug and its sealing ring, and keep them for re-use. Check the oil level by looking into the filler hole – the oil level should be just below the bottom of the threaded filler hole, which extends to 23mm (0.9 inch) from the upper surface. If it is low, then top up to the bottom of the threaded hole with 50cSt silicone fluid – don't use any other type of oil. Replace the filler cap and sealing ring. It is essential that the oil in the reservoir stays completely clean – take care not to add any dirt or grit via the filler.
4. Look at the reservoir breather vent entry, and make sure it is clear of debris.
5. Observe the control box interior, and make sure that the wiring, the limit switch(es), the solenoid valve, the fuse board etc. are in good condition. Any damaged components should be replaced. In order to replace any control box component, first disconnect the motor and solenoid wires from the upper connector block on the fuse board (see page 9), then undo the three screws holding down the limit switch plate assembly (see page 5) and lift out this assembly complete with shaft and fuse board. When this has been done, all the components become easily accessible either on the plate assembly or in the disencumbered control box.
6. Make sure that the top shaft seal O-ring is in good condition and well greased – this is necessary to ensure that the control box remains weather-tight.
7. Replace the control box lid, taking care that the lid flange O-ring is well seated in its groove and that no wires are trapped between the lid and the control box. Replace the position indicator.

Troubleshooting guide

This is a guide to simple problems only – contact Kinetrol's distributor if this does not solve your problem.

<u>PROBLEM</u>	<u>POSSIBLE CAUSE</u>	<u>ACTION</u>
Irregular motion under power.	Load takes too much torque. Incorrect supply voltage. Lack of oil.	Fit larger model actuator. Correct it. Find where oil has gone: Was axis orientation correct? If not, correct it (see page 4). If there is a leak, correct it. Refill with oil.
Pump fails to stop at end of power stroke.	Striker maladjusted. Limit switch failed.	Reset striker. Replace limit switch.
Actuator drops back when holding at end of power stroke.	Damaged solenoid valve.	Replace solenoid valve.
Spring stroke slow or irregular.	Load takes too much torque. Oil debris blocking solenoid valve.	Fit larger model actuator. Clear out debris from valve.
Complete failure to run.	Fuse blown.	Replace fuse – if it blows again, trace fault. <u>Note:</u> high voltage transients can blow the fuse as part of the protective action of the MOV suppressor device.
Solenoid clicks but pump dead.	Limit switch failed.	Replace limit switch.